



MILLENNIAL LINE

SERVICE BOOK

INDEX

READING THE OVEN'S LABEL.....	3
MILLENNIAL LINES.....	4
TS LINE FEATURES.....	5
BM LINE FEATURES.....	6
S LINE FEATURES.....	7
TROUBLESHOOTING TOUCH SCREEN.....	8
TROUBLESHOOTING BLACK MASK.....	9
TROUBLESHOOTING SMART.....	10
ALARM MESSAGES TOUCH SCREEN.....	11
WARNING MESSAGES TOUCH SCREEN.....	14
ALARM MESSAGES BLACK MASK.....	15
QR CODES MAINTENANCE VIDEOS.....	17
ONLINE ACCESS PROCEDURE.....	19
OVEN'S INSTALLATION.....	21
MAIN SOURCES ON THE WALL.....	22
KITCHEN POSITIONING.....	23
ELECTRICAL CONNECTION.....	24
WATER SUPPLY.....	25
DRAINAGE CONNECTION.....	27
COMPONENTS LOCATION IN THE OVEN.....	31
HOOD INSTALLATION FOR TWO STACKED OVENS.....	32
GASKET CLEANING PROCESS.....	35
SAFETY THERMOSTAT DEVICE POSITION.....	36
CABLE ARRANGEMENT FOR ACCESSORIES BOARD.....	37
SOFTWARE INSTALLATION AND UPDATE TOUCH SCREEN.....	38
SOFTWARE RESET AND RE-INSTALLATION TOUCH SCREEN.....	39
SOFTWARE INSTALLATION AND UPDATE BLACK MASK.....	39
DISPLAY REPLACING.....	41
WASHING SYSTEM INSTALLATION (FOR BLACK MASK MODELS).....	45
TOUCH SCREEN CONTROL PANEL.....	57
BLACK MASK CONTROL PANEL.....	61
ACCESSORIES AVAILABLE FOR GASTRONOMY OVENS.....	64
ACCESSORIES AVAILABLE FOR BAKERY&PASTRY OVENS.....	68

READING THE OVEN'S LABEL

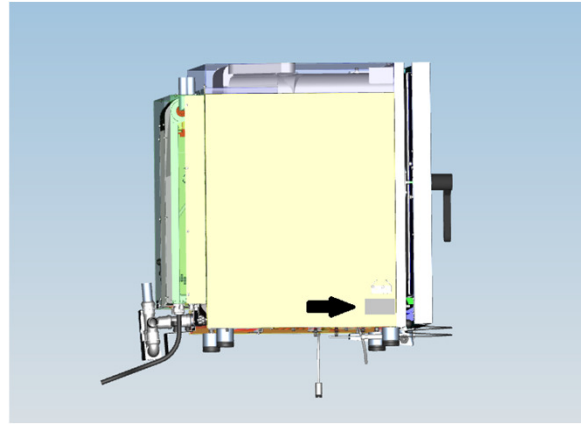

MKF 6 11 V CTS P

Famiglia
Family
M Millennium

Marchio
Brand
K Eka

Prodotto
Product

F forno
oven

FD forno deck
deck oven

KC cappa a condensazione
condensation hood

LM lievitatore e mantentore
proofers and holding cabinet

L lievitatore
proofers

M mantentore
holding cabinet

CR carrello
trolley

T tavolo
table

TS tavolo con supporti
table with supports

TPL tavolo polli
closet

S kit sovrapposizione forni
kit for overlapping ovens

ST kit sovrapposizione tavoli
kit for overlapping tables

SST kit sovrapposizione forni con supporti teglie
kit for overlapping ovens with trays supports

SCMU sonda al cuore multipunto
multi-point core probe

SCMO sonda al cuore monopunto
single-point core probe

SCSV sonda al cuore sottovuoto
vacuum cooking core probe

SSC/A supporto sonda al cuore
support for core probe

AF affumicatore
smoker

CG concentratore grasso
fat concentrator

WT sistema di lavaggio automatico
automatic washing system

DET detergente e brillantante
detergent and rinse aid

KR kit ruote
set of wheels

KD kit doccia
spray kit

KAF addolcitore LT, 8
water softener LT,8

TA testata di connessione cartuccia filtrante
per trattamento acqua potabile
filter head for water optimisation

CA cartuccia filtrante per trattamento acqua potabile
filter for water optimisation

KPI kit prima installazione
first installation kit

KPIC kit prima installazione (compact)
first installation kit (compact)

CKIT kit cappa Millennium
Millennium condensation hood kit

Caratteristiche Linea
Line Features
P pratico
practical

Linea
Line
S smart
BM black mask
TS touch screen

Linea forno
Oven line
C compact
(larghezza 500 mm)
(width 500 mm)

Caratteristiche
Features
D double
(per sovrapposizione
forni)
(for overlapping ovens)
V boiler
G gas

Tipologia di teglia
Tray dimension
11 1/1 GN
21 2/1 GN
23 2/3 GN
64 600 x 400 mm

Numero teglie
Number of trays
1 una teglia
one tray
2 due teglie
two trays
4 quattro teglie
four trays
5 cinque teglie
five trays
6 sei teglie
six trays
7 sette teglie
seven trays
10 dieci teglie
ten trays
11 undici teglie
eleven trays
12 dodici teglie
twelve trays
16 sedici teglie
sixteen trays
20 venti teglie
twenty trays

Millennial lines



TOUCH SCREEN LINE



BLACK MASK LINE



SMART LINE

TS LINE FEATURES



- TFT 7" capacitive 800x480 colour touch screen panel
- Knob with scroll and push function
- Three patents: Airflowlogic™, Humilogic™, Drylogic™
- Automatic washing system integrated
- Multipoint core probe
- Temperature range of electric ovens from 30°C to 270°C gas ovens from 30°C to 260°C
- 10 programmable cooking phases
- Direct steam controlled by touch screen (10 steps)
- Preheating
- Holding
- Fast cooldown
- Cooking chamber in AISI 304
- Inspectionable door glass
- Water protection: IPX3, IPX4, IPX5
- USB socket
- HACCP system
- Condensate collection bowl, with drain on door
- Hinge with door locking for openings adjusted at 60°, 90°, 120°, 180°
- Delayed start programmable up to 24h
- Possibility to control the proofing and holding cabinet
- Favourite recipes quick settings
- Programmable recipes: 500
- 42 languages
- Adjustable feet

BM LINE FEATURES



- TFT 7" black mask capacitive electronic control
- One patent: Airflowlogic™
- Ease of use
- Temperature range from 30°C to 270 °C
- 10 programmable cooking phases
- Direct steam controlled by the black mask panel (10 by 10 from 0% to 100%)
- Preheating
- Holding
- Fast cooldown
- Cooking chamber in AISI 304
- Inspectionable door glass
- Water protection: IPX4
- USB socket
- HACCP system
- Ready for core probe connection (built-in socket)
- Ready for automatic washing system
- Condensate collection bowl, with drain on door
- Hinge with door locking for openings adjusted at 60°, 90°, 120°, 180°
- Delayed start programmable up to 24h
- Possibility to control the proofing and holding cabinet
- Programmable recipes: 100
- Adjustable feet

S LINE FEATURES



- Electromechanical panel
- Ease to use
- Cooking timer from 10' to 120' /infinite mode
- Temperature range from 100°C to 275 °C
- Direct steam controlled by a knob (5 steps)
- Cooking chamber in AISI 304
- Inspectionable door glass
- Water protection: IPX4
- Ready for manual washing system (shower kit)
- CB certificated
- Condensate collection bowl, with drain on door
- Hinge with door locking for openings adjusted at 60°, 90°, 120°, 180°
- Adjustable feet



Cooking time/infinite mode

Cooking temperature

Humidity indicator

TROUBLESHOOTING TOUCH SCREEN OVENS

Type of fault	Cause of fault	Corrective action
Control panel totally off (the oven does not work)	Non-compliant connection to the power mains	Check the connection to the mains
	No mains voltage	Restore the power supply voltage
	Blown electronic board protection fuse (with microprocessor)	Check and change the fuse
Cooking cycle on: the oven does not start up	Door open or ajar	Close the door properly
	Door magnetic sensor damaged	Check it and change it
Steam cycle on: no steam is being generated in the cooking chamber	Non-compliant water mains connection	Check the connection to the water mains
	Closed stopcock	Check the stopcock
	Obstructed water inlet filter	Clean the filter
	Damaged water inlet solenoid valve	Check and change the valve
	Steam generator safety thermostat on	Change the steam generator (if you can't change just the thermostat)
Closed door: steam escapes through the gasket	Non-compliant gasket assembly	Check gasket assembly
	Damaged gasket	Change the gasket
	Loosened handle "nose"	Tighten the "nose"
The oven does not cook evenly	One of the motors is down or operates at low speed	Check it and change it
	The motors do not reverse direction	Check for reversion







TROUBLESHOOTING BLACK MASK OVENS













Type of fault	Cause of fault	Corrective action
Control panel totally off (the oven does not work)	Non-compliant connection to the power mains	Check the connection to the mains
	No mains voltage	Restore the power supply voltage
	Blown electronic board protection fuse (with microprocessor)	Check and change the fuse
Cooking cycle on: the oven does not start up	Door open or ajar	Close the door properly
	Door magnetic sensor damaged	Check it and change it
Steam cycle on: no steam is being generated in the cooking chamber	Non-compliant water mains connection	Check the connection to the water mains
	Closed stopcock	Check the cock
	Obstructed water inlet filter	Clean the filter
	Damaged water inlet solenoid valve	Change the valve
	Steam generator safety thermostat on	Change the steam generator (if you can't change just the thermostat)
Closed door: steam escapes through the gasket	Non-compliant gasket assembly	Check gasket assembly
	Damaged gasket	Change the gasket
	Loosened handle "nose"	Tighten the "nose"
The oven does not cook evenly	One of the motors is down or operates at low speed	Check it and change it
	The motors do not reverse direction	Check for reversion













TROUBLESHOOTING SMART

Type of fault	Cause of fault	Corrective action
Control panel totally off (the oven does not work)	Non-compliant connection to the power mains	Check the connection to the mains
	No mains voltage	Restore the power supply voltage
	Safety thermostat device triggered	Restore the safety thermostat device
Cooking cycle set: the oven does not start up	Door open or ajar	Close the door properly
	Door magnetic sensor damaged	Check it and change it
Automatic humidifier active: no steam is being generated in the cooking chamber	Non-compliant water mains connection	Check the connection to the water mains
	Closed stopcock	Check the cock
	Obstructed water inlet filter	Clean the filter
	Damaged water inlet solenoid valve	Change the valve
Closed door: steam escapes through the gasket	Non-compliant gasket assembly	Check gasket assembly
	Damaged gasket	Change the gasket
	Loosened handle "nose"	Tighten the "nose"
The oven does not cook evenly	One of the motors is down or operates at low speed	Check and change
	The motors do not reverse direction	Check for reversion and change
	Resistors not powered or damaged	Check it and change it
Lamp (LED) in the cooking chamber does not work	Lamp (LED) damaged	Replace the lamp (LED)
The thermostat safety device is continuously activated	Damaged device	Check it and change it
	Cooking chamber thermostat control damaged	Check it and change it











ERROR LIST TOUCH SCREEN

Type	Description	Cause	Effect	Corrective action
E01	 Temperature probe not detected	Cooking chamber probe- electronic board/ microprocessor connection down	Cooking cycle cannot be started	Check and change the cooking chamber probe
		Damaged cooking chamber probe		
E02	 Core probe not detected	"Core" probe- electronic board/microproces sor connection down.	Impossible to start a cooking cycle which requires setting the "core" temperature parameter	Connect the core probe to the oven, if there is still the error, check it and change it.
		Damaged (needle- shaped) "core" probe		
E03	 Overheated motors safety circuit breaker tripped	Overheated motor (tripped motor thermal protection)	Oven operation disabled	Check the placement of the oven (as described at the beginning) and check the tangential motor fan
E04	 Maximum oven operating temperature exceeded; tripped safety thermostat	Safety thermostat on	Oven operation disabled	Disable the safety thermostat as shown later. Check if it works properly.
E05	 Display board exceeded the temperature of 75°C	Inner glass not properly closed; gasket in bad conditions	Oven operation disabled	Check if the inner glass is properly closed; check the gasket conditions; change the board if necessary
E06	 Main power board S024 exceeded the temperature of 75°C	Cooling fan not working; oven too close to hot equipment or built in; oven without feet; protective film not removed	Oven operation disabled	Check all the causes; change the board if necessary
E07	 Auxiliary power board S025 overtemperature exceeded the temperature of 75°C	Overtemperature above 75°C on the auxiliary power micro card	Oven operation disabled	Check all the causes; change the board if necessary

I08		Door open close the door to continue cooking	Door opening during the cooking cycle	Cooking cycle stopping	Close the oven door
I09		Door closed open the door to cool the oven	“Fast cooling” function enabled with door closed	Oven operation disabled	Open the oven door to allow “Fast cooling” of the cooking chamber
E08		Hood control board exceeded the temperature of 75°C	The hood is not electrically connected; the motor/fan is not working	Hood operation disabled	Check if the motor/fan is working properly; change the board
E09		Proofer/holding cabinet board exceeded the temperature of 75°C	Cabinet too close to the wall, not enough ventilation	Cabinet operation disabled	Move the cabinet farther from the wall; change the board if needed
E10		Poorly placed glass, move the glass upwards	Wrong position of the door glass	Oven operation disabled	Place the door glass up
E11		Poorly placed glass, move the glass downwards	Wrong position of the door glass	Oven operation disabled	Place the door glass down
E12		Main board S024 communication error	Touch board – power board S024 miscommunication error, check the data cable connection between the two boards or replace the main power board as faulty	Oven operation disabled	Contact TECNOEKA for further information
E13		Auxiliary board S025 communication error	Wrong installation of the software	Oven operation disabled	Contact TECNOEKA for a new firmware
E14		Hood board communication error	Wrong installation of the software	Oven operation disabled	Contact TECNOEKA for a new firmware
E15		Proofer board communication error	Wrong installation of the software	Oven operation disabled	Contact TECNOEKA for a new firmware
E16		Holding cabinet board communication error	Wrong installation of the software	Oven operation disabled	Contact TECNOEKA for a new firmware
E17		S024 board firmware error	Wrong installation of the software	Oven operation disabled	Contact TECNOEKA for a new firmware
E18		S025 board firmware	Wrong installation of the software	Oven operation	Contact TECNOEKA for a

E19		T011 board hood firmware error	Wrong installation of the software	Oven operation disabled	Contact TECNOEKA for a new firmware
E20		T011 board proofer firmware error	Wrong installation of the software	Oven operation disabled	Contact TECNOEKA for a new firmware
E21		T011 board holding cabinet firmware error	Wrong installation of the software	Oven operation disabled	Contact TECNOEKA for a new firmware
E22		Humidity database not detected	No database	Oven operation disabled	Reload the FW. Contact TECNOEKA for updates
E23		No Factory Recipe Book	No database	Oven operation disabled	Reload the FW. Contact TECNOEKA for updates
E24		No User Recipe Book	No database	Oven operation disabled	Reload the FW. Contact TECNOEKA for updates
E25		STOP GAS	The oven burner does not turn on, as there is no gas.	Oven operation disabled	Check the flame control device and the electrodes group
E26		T011 board gas firmware error	Wrong installation of the software	Oven operation disabled	Reload the FW. Contact TECNOEKA for updates
E27		GAS settings database not found	No database	Oven operation disabled	Reload the FW. Contact TECNOEKA for updates
E28		Blower not active	The oven burner does not turn on due to a failure on the electrical winding/mechanical block of the "blower".	Oven operation disabled	Check the connections to the blower
E29		Check the exhaust valve lever position	Valve lever in the wrong position	Water in the tank/grease in the drain	Move the lever according to the program (cooking or washing)
E30		Hood not electrically connected	Hood unplugged	The hood doesn't work, it can be damaged	Connect the hood to the electrical socket

ERROR LIST TOUCH SCREEN (WARNING MESSAGES)

Type	Description	Cause	Corrective action
	 Blackout the oven was off from xx:xx to yy:yy	Power cut off for a period of time during the cooking cycle	The oven automatically resumes the cooking cycle when the power supply is restored
W01	 Display board exceeded the temperature of 65°C	Inner glass not properly closed; gasket in bad conditions	Check if the inner glass is properly closed; check the gasket conditions; change the board if necessary
W02	 Main power board exceeded the temperature of 65°C	Cooling fan not working; oven too close to hot equipment or built in; oven without feet; protective film not removed	Check all the causes; change the board if necessary
W03	 Auxiliary power board exceeded the temperature of 65°C	Overtemperature above 65°C on the auxiliary power micro card	Check all the causes; change the board if necessary
W04	 Hood board exceeded the temperature of 65°C	The hood is not electrically connected; the motor/fan is not working	Check if the motor/fan is working properly; change the board
W05	 Proofer/holding cabinet board exceeded the temperature of 65°C	Positioning of the cabinet	Check the position as shown before
W06	 Humidification malfunction, cannot reach the desired humidity.	Insufficient humidity in the cooking chamber	Check if the solenoid valve and flow regulators works properly
W07	 Dryer malfunction cannot reach the desired humidity".	Excessive humidity in the cooking chamber	Check if the axial motor fan works properly
W08	 Wash oven - excessive number of cooking cycles executed without washing the oven	Too many cooking cycles executed without washing	Start a washing cycle.
W09	 Faulty heating resistors	Excessive time taken to reach the required temperature	Check and change the resistors

ERROR LIST BLACK MASK

Type	Description	Cause	Effect	Corrective action
E01	Temperature probe not detected	Cooking chamber probe-electronic board connection down	Cooking cycle cannot be started	Check and change the cooking chamber probe
		Damaged cooking chamber probe		
E02	Core probe not detected	Core probe-electronic board connection down.	Impossible to start a cooking cycle which requires setting the "core" temperature parameter	Connect the core probe to the oven, if there is still the error, check it and change it.
		Damaged (needle-shaped) "core" probe		
E03	Maximum oven operating temperature exceeded; tripped safety thermostat	Safety thermostat on	Oven operation disabled	Disable the safety thermostat as shown later. Check if it works properly.
E04	Overheated motors safety circuit breaker tripped	Overheated motor (tripped motor thermal protection)	Oven operation disabled	Check the placement of the oven (as described at the beginning) and check the tangential motor fan
E05	Blower not active (16-20 trays oven)	The oven burner doesn't turn on due to failure on the electrical winding/mechanical block of the blower	Oven operation disabled	Check the connection with the blower, change it if needed
E06	Stop gas (until 5 times trying)	The oven burner does not turn on, as there is no gas.	Oven operation disabled	Check gas connection
E07	Stop gas (after the fifth try)	The oven burner does not turn on	Oven operation disabled	Check the gas control board, check the spark plug.

E08	Display board exceeded the temperature of 75°C	Inner glass not properly closed; gasket in bad conditions	Oven operation disabled	Check if the inner glass is properly closed; check the gasket conditions; change the board if necessary
E09	Main power board exceeded the temperature of 75°C	Cooling fan not working; oven too close to hot equipment or built in; oven without feet; protective film not removed	Oven operation disabled	Check all the causes; change the board if necessary
E10	Automatic washing cycle cannot be activated	The temperature in the cooking chamber is over 90°C	The automatic washing cycle does not work	Cool the cooking chamber: open the door and touch the symbol of cooling down (look at page ...)
E11	Condensation hood not working	The cable is not connected	Oven operation disabled, if there is a cooking on going it will be stopped.	Check the proper connection of the hood to the mains.
E12	Hood condensation temperature probe not working	Connection broken between hood temperature probe and electronic board	Oven operation disabled, if there is a cooking on going it will be stopped.	
E13	Proofer temperature probe not detected	Connection broken between temperature probe and micro power board	Cannot start the proofing cycle	
E14	Holding cabinet temperature probe not detected	Connection broken between temperature probe and micro power board	Cannot start the holding cycle	
E15	Poorly placed glass, move the glass downwards	Wrong position of the door glass	Oven operation disabled	Place the door glass down
E16	Poorly placed glass, move the glass upwards	Wrong position of the door glass	Oven operation disabled	Place the door glass up
E18	Blackout	Power cut off for more than one minute	Oven operation disabled	When turn on again the oven shows the cooking program that was running. Resume it.
E20	Micro power board not detected	The display board does not communicate with the micro power board	Upgrade the board firmware	Contact TECNOEKA for the upgrade file
E25	Check the exhaust valve lever position	Valve lever in the wrong position	Water in the tank/grease in the drain	Move the lever according to the program (cooking or washing)

MAINTENANCE VIDEO – QR CODES



1 SOFTWARE



OVEN'S UPDATE



FACTORY RESET



RECIPE PICTURE
UPLOAD



IMPORT-
EXPORT
PROGRAMS

2 PARTS REPLACEMENT



GASKET
REPLACEMENT



DRYLOGIC
REPLACEMENT



MOTOR
REPLACEMENT



FAN
REPLACEMENT



HIGH LIMIT
SWITCH REPLACEMENT



HEATING ELEMENT
REPLACEMENT

3 POWER BOARD



FUSES CONTROL



INSPECT
POWER BOARD
CABLES

MAINTENANCE VIDEO – QR CODES



4 DOOR MAINTENANCE



TOUCH SCREEN
REPLACEMENT



ENCODER
REPLACEMENT



OUTER GLASS
REPLACEMENT



INNER GLASS
REPLACEMENT



COMPLETE DOOR
SET REPLACEMENT

5 GAS



GAS JET
REPLACEMENT

EXPLODED DIAGRAMS



TECHNICAL DATA SHEET AND WIRING DIAGRAMS



INSTRUCTIONS FOR LOGIN / ACCESS EKA WEBSITE RESERVED AREA

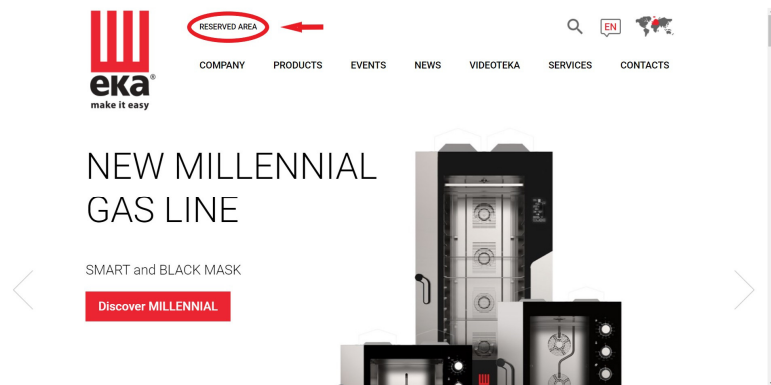

1. Tap www.tecnoeka.com and click on «RESERVED AREA»

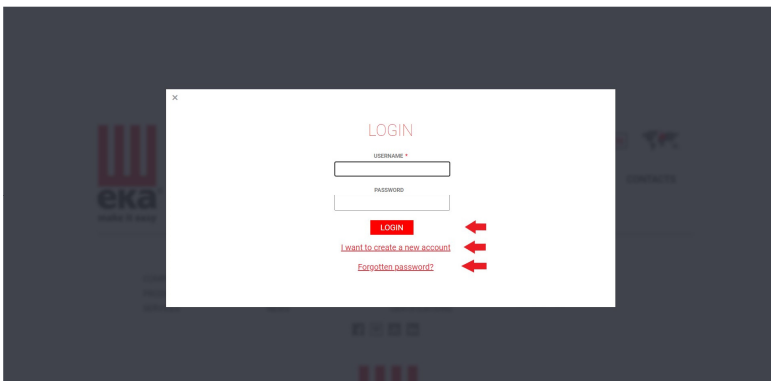

2. If you have already registered click on «LOGIN»

If you have not registered yet click on «I want to create a new account»

Click on «Forgotten password?» in case you forgot registration credentials

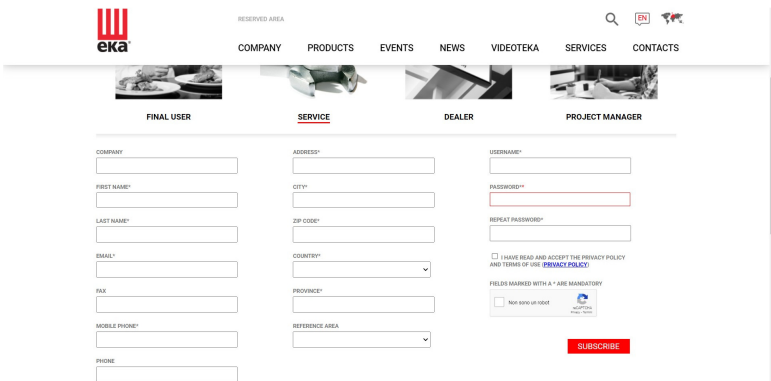

3. Fill all data required in the form, confirmation e-mail will be then sent on the specified email address

4. Click on the link received by email to activate the account

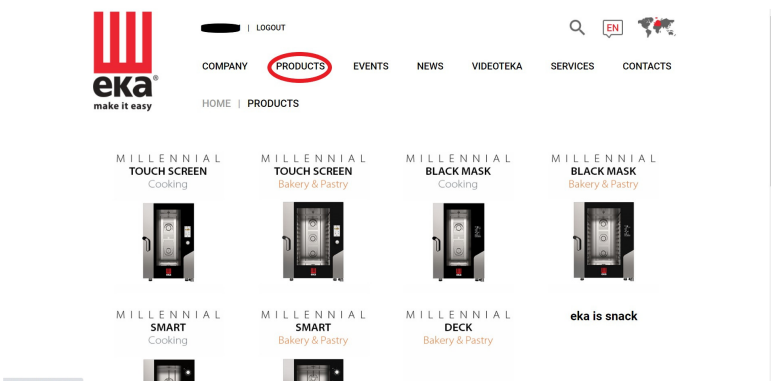

5. Once logged in the RESERVED AREA, click on «PRODUCTS» to expand all products line up and possible configurations (e.g. TOUCH SCREEN – Cooking)

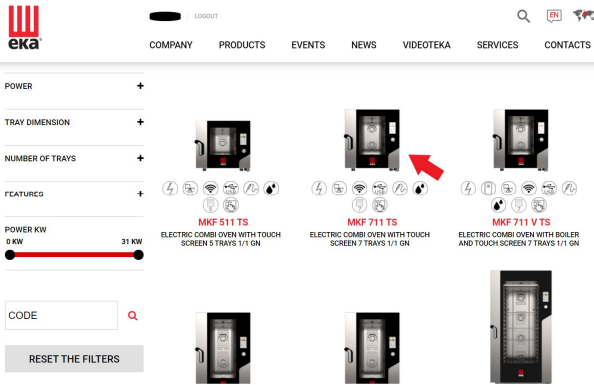

6. Select the oven you are looking for documentation (e.g. MKF 711 TS)

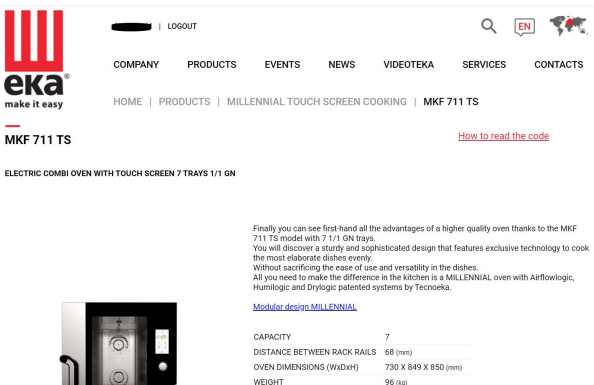

7. Scroll to the end of the page to recall «DOWNLOAD»

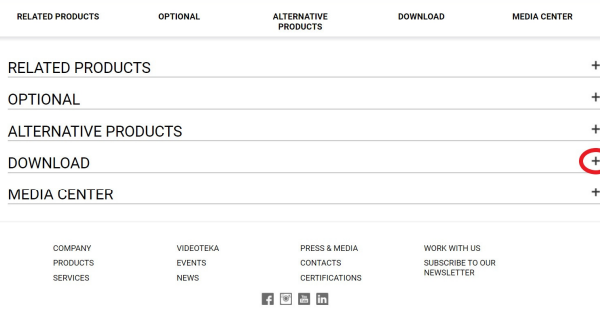

8. Click on the marked «+» to view all documents available for download

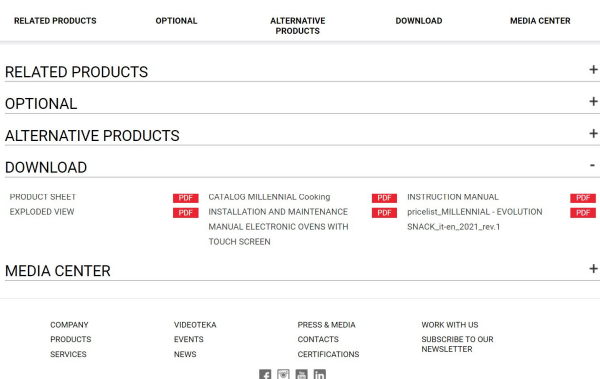

9. Download the file you need by clicking on it

OVEN INSTALLATION FEATURES

MAIN SOURCES ON THE WALL

If you are installing a complete solution (oven, hood and prover/holder) you will need the following sources on the wall



No.3 cold water taps, male fitting 3/4"



No.1 PVC discharge 32mm diameter, recommended ground height 50cm



No.1 pentapolar (red) three-phase socket from 16A



No.1 single-phase 16A schuko

Here below the 5 key points to be observed in order to perform the right installation

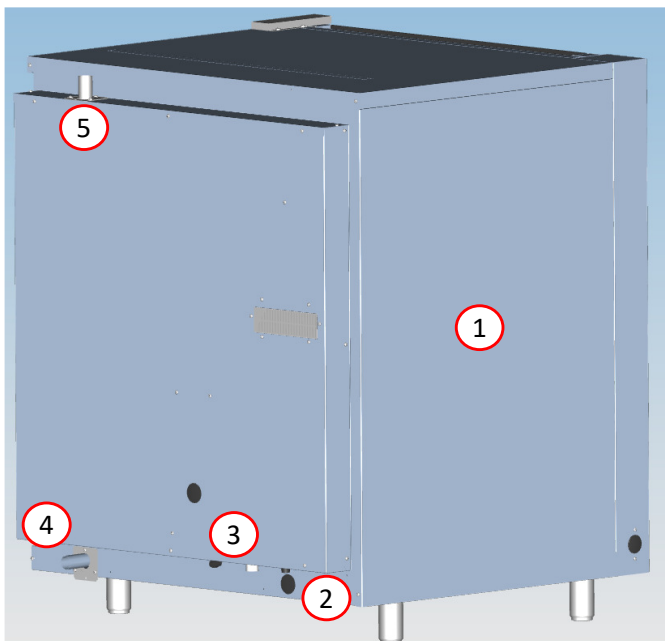

- ① POSITIONING OF THE UNIT IN THE KITCHEN
- ② ELECTRICAL CONNECTION
- ③ WATER SUPPLY
- ④ DRAINAGE CONNECTION
- ⑤ EXHAUST CONNECTION

KITCHEN POSITIONING

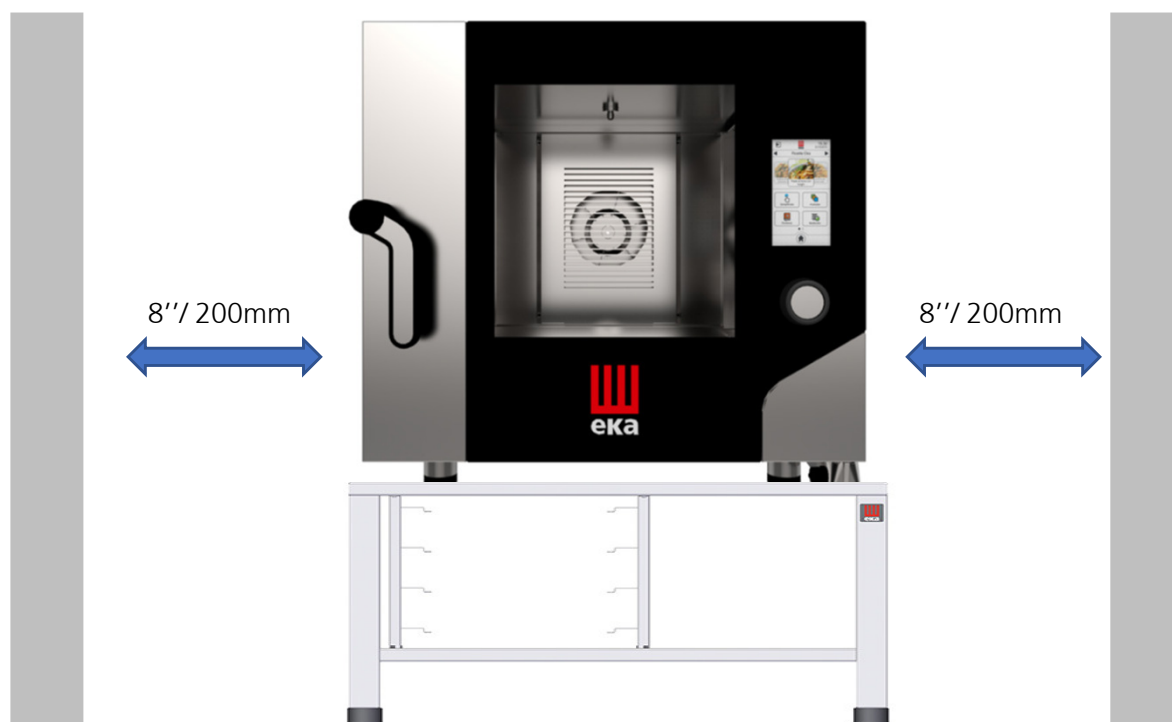

Check the place of installation making sure that the transit areas (any doors and corridors) are sufficiently wide and the floor supports the appliance weight. The appliance must be transported with mechanical means (e.g. pallet jack). The installation rooms must be well-ventilated with permanent aeration vents; must be equipped with the proper electrical and hydro systems, built in accordance with the standards related to facilities and workplace safety in the country of installation.

The maximum working height, referring to the highest surface level, must be 1.6 metres from the floor.

To facilitate air circulation around the appliance, leave a space of about 20cm between the appliance sides and the surrounding walls (or other appliance), and between the back and the wall. The appliance must be positioned in order that the back side has to be easily accessible to set up various electrical connections and to carry out any possible maintenance. Do not install the appliance near any equipment that may reach high temperature values (e.g. deep fryers). The appliance can be installed near walls, shelves, counters and similar, these, however, must be non-flammable or heat-resistant; otherwise, they must be protected by adequate fire-retardant coating. Accordingly, it is mandatory to act in compliance with the fire prevention regulations in force.

Cooking produces hot smoke/vapour and odours which are extracted through the suitable vent device located at the top of the appliance.

It is recommended to place the appliance under an extraction hood or to use the suitable TECNOEKA condensation hoods in order to convey the smoke/vapour to the outside.

Warning

Make sure there are no objects and/or materials obstructing the oven's exhaust device. The hot smoke/vapour produced during cooking must run freely out of the exhaust device in order not to compromise the regular operation of the oven. Inflammable materials must not be left near the oven's exhaust device.

Table top oven placement

The appliance must be placed in a perfectly horizontal position on a table or similar support; never on the floor. To facilitate oven levelling, the feet are adjustable in height. For safety reasons, it's recommended to use the specific table produced by TECNOEKA; otherwise the dimensions and weight of the appliance must be taken into account. The appliance is unsuitable for recessed installation and cannot work without the 4 supporting feet.

Warning

If the appliance is positioned on a wheeled table/support, ensure that the intended movement does not damage electrical wires, water pipes, drain pipes or anything else.

Stacking ovens on other appliances

When stacking two appliances only the specific "STACKING KIT" supplied by TECNOEKA can be used.

THE MANUFACTURING COMPANY DISCLAIMS ANY LIABILITY FOR DIRECT OR INDIRECT DAMAGES CAUSED BY THE FAILURE TO COMPLY WITH THIS DIRECTIVE.

For correct "STACKING KIT" installation operations, follow the instructions provided inside the package.

Warning

An oven must never be stacked directly on another oven or another heat source.

Placement of 16-20 trays ovens with trolley

The appliance must be placed on a flat and level floor that can sustain the weight of a "full load" without collapsing or deforming. After placement, make sure that the appliance is aligned horizontally. This check may be carried out by placing a level (bubble or digital) on the 4 top sides of its casing.

Ensure that the tray trolley is able to go in and out of the cooking chamber easily, without rubbing against the lower surface, even with "full load". Otherwise the appliance feet must be adjusted to lower it so that the tray trolley can move properly. In any case, when the adjustment is complete, ensure that the wheels of the tray trolley inserted in the cooking chamber are raised off the floor (not more than 5 mm), and the trolley is supported by the guides at the bottom of the appliance.

The tray trolley must be moved using the supplied removable handle. This must be inserted into its places completely.

The tray trolley must be inserted inside the cooking chamber, freely sliding on the guides in the lower portion of the appliance.

Warning

The appliance may malfunction unless the tray trolley is correctly positioned.

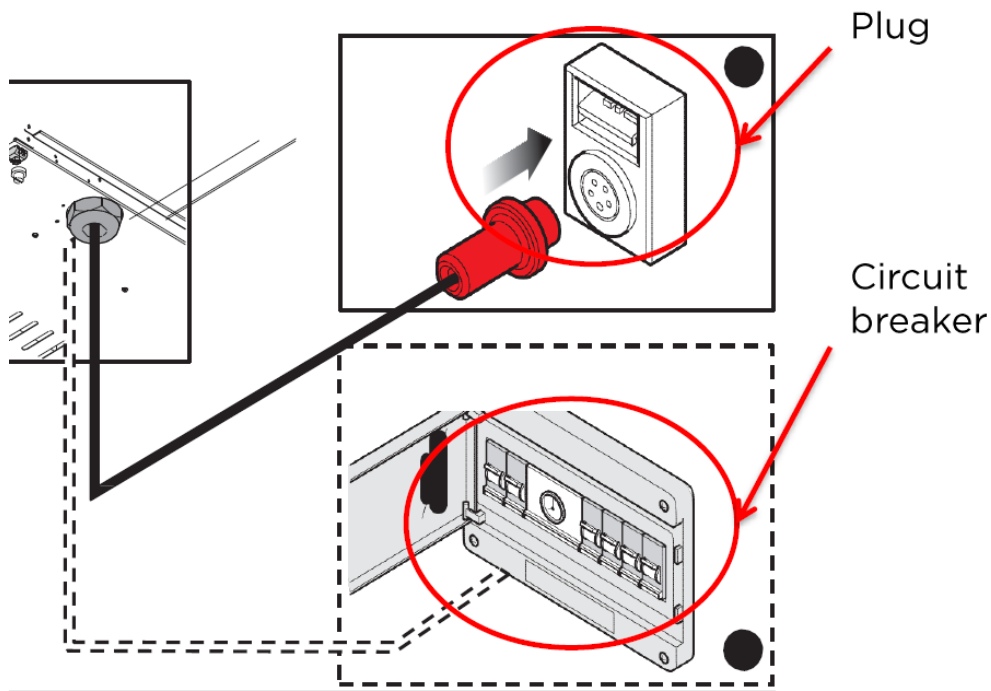

Before making the connections, make sure that the voltage and frequency of the power supply system match the specifications of the "technical data" plate affixed to the appliance.

- The appliance must be connected to a suitable equipotential system
- If the power supply cable is damaged, it must be replaced by the manufacturer or their technical support service, or in any case by a person with similar qualifications, to prevent any risk.
- If the oven is placed on a wheeled table, the connection conduit must be flexible. The table wheels must be blocked with specific brakes.

Warning

Any electric connection must be made by qualified technical personnel.

Appliances supplied without power cable:

Remove the appliance's rear panel to access the power terminal block.

Mount the specific conduit and make the power cord conductors pass through until they reach the terminal board.

Connect the phase conductors to terminals "L1", "L2" and "L3" of the terminal board, the neutral to terminal "N" and the earth conductor to the terminal with the following symbol .



NOTES

- The electrical system must be fitted with a pole circuit breaker with rated breaking current equal to 150% of the current consumed by the appliance.
- The circuit breaker must be installed near the appliance and the operator must be able to access it at any time

WATER SUPPLY

The appliance must be supplied with softened drinking water. It is mandatory to use a filter to reduce the formation of limescale into the cooking chamber.

The water pressure must range between 100 kPa and 200 kPa (1.0-2.0 bar).

If the mains pressure exceeds 200 Kpa, install a pressure reducer between the tap and the appliance.

If the value is lower than 100Kpa use a pump to raise the pressure. The water temperature must not exceed 86°F (30°C).

Connection to the water mains must be performed through the ¾" threaded solenoid valve located at the rear (bottom) of the appliance, interposing a mechanical filter and a stopcock (before connecting the filter drain off a certain amount of water to flush the pipe from any dirt).

To guarantee the correct operation of the appliance, the inlet water must be suitably treated in order to reach the requirements below:

Without chlorine ---> Less than 0.1 ppm (mg/L)

Hardness ---> 30-70 ppm

Chloride ---> Less than 30 ppm (mg/L)

pH ---> from 7.0 to 8.5

Silica ---> Less than 12 ppm (mg/L)

Total dissolved solvents (TDS) ---> 50-125 ppm

Failure to reach these features may damage the appliance and/or its internal components.

NOTE Any damage caused by limescale or other chemicals contained in the water are not covered by warranty

To check the hardness and conductivity of the water and therefore to establish if a cartridge filter or a Reverse osmosis kit needs to be used, a water test needs to be carried out as described here below.

- Measure the total conductivity using the electronic meter and read the value to the display. The value shown represents the total hardness of the water due to the presence of calcium carbonates, magnesium, metals chloride, chloramines, sodium etc, measured in **μSiemens/cm**

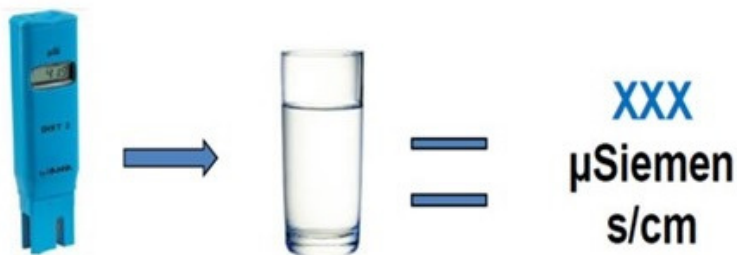

- Carry out the temporary hardness test kit for calcium carbonate and magnesium only. The test is carried out by taking 5ml of tap water and adding one drop at the time of the chemical until the solution becomes a bright yellow color
- The number of drops that are used represent the hardness in German degrees (°d). This value has to be multiplied by 30 to provide the temporary hardness in μSiemens/cm

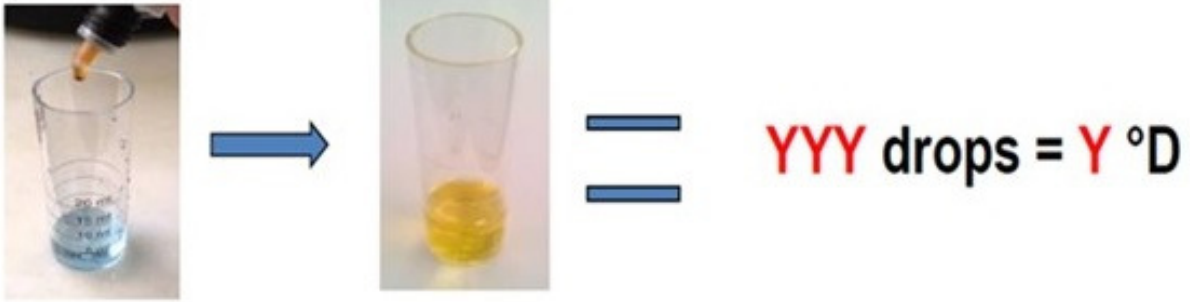

Subtract the **YYY** $\mu\text{Siemens/cm}$ (*YYY drops multiplied by 30*) from the **XXX** $\mu\text{Siemens/cm}$

$$\text{XXX} - \text{YYY} = \text{JJJ} \mu\text{Siemens/cm}$$

- Detract the value of the temporary hardness from the value of the total conductivity.
- Compare the result with the required limits of hardness for the incoming water (**for steam purpose only**)

Conclusion

- If **JJJ** is < than 150 $\mu\text{Siemens/cm}$, the oven do not require a Reverse osmosis kit to treat the incoming water tap (for steaming purpose only).
 - If the **Y** value is inferior/equal to 4°d as temporary hardness (or 7°f), the oven do not require the Cartridge filter neither
 - If the **Y** value is higher than 4°d as temporary hardness, the oven require the Cartridge filter
- If **JJJ** is > 150 $\mu\text{Siemens/cm}$, the oven require the Reverse osmosis kit

CONVERSION CHART

1°d = 0,64 ppm TDS

1°d = 1,8 °f

1°d = 30 $\mu\text{Siemens/cm}$

Water inlet for humidification / steam

The appliance is equipped with a standardised flexible hose (1.5 metres) with threaded $\frac{3}{4}$ " female fittings and relative gaskets. Old joints and old hose-sets must not be re-used.

The appliance must be supplied with softened water with hardness between 0.5°f and 3°f. It's mandatory to use a softener to reduce the formation of limescale inside the cooking chamber. THE MANUFACTURING COMPANY DISCLAIMS ANY LIABILITY FOR DIRECT OR INDIRECT DAMAGE CAUSED BY FAILURE TO COMPLY WITH THIS DIRECTIVE.

The connection to the water mains must be set up through the $\frac{3}{4}$ " threaded solenoid valve located on the back (at the bottom) of the appliance, using the supplied flexible hose, with a mechanical filter and stopcock installed in between (before connecting the filter, drain off a certain amount of water to flush any dirt out of the hose).

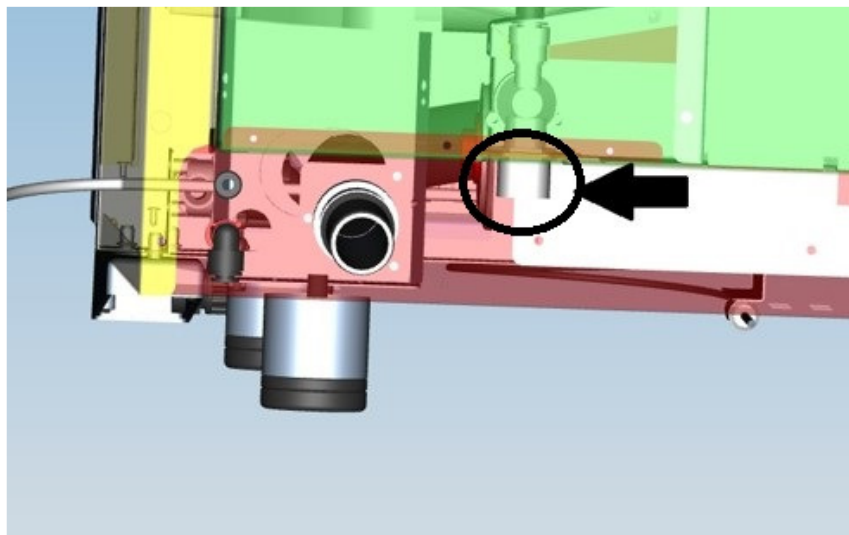
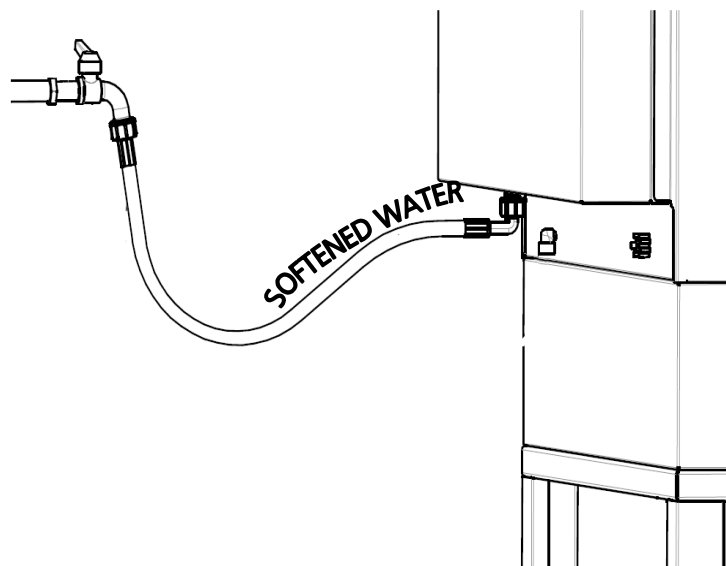

Warning

Any damage caused by limescale, other chemicals contained in the water, or usage of a different detergent from the recommended one are not covered by warranty.

Washing water inlet (*TS models and BM with washing system*)

The unit is equipped with a flexible polyethylene hose (2 meters) with quick fitting on one end, $\frac{3}{4}$ " threaded female with relative gasket on the other end, and a special mechanical filter.

Old joints must not be re-used.

The appliance must be supplied with drinking water.

The connection to the water mains must be set up through the quick fitting located on the back (at the bottom) of the appliance, using the supplied flexible hose, with a supplied mechanical filter and stopcock installed in between (before connecting the filter, drain off a certain amount of water to flush any dirt out of the hose).

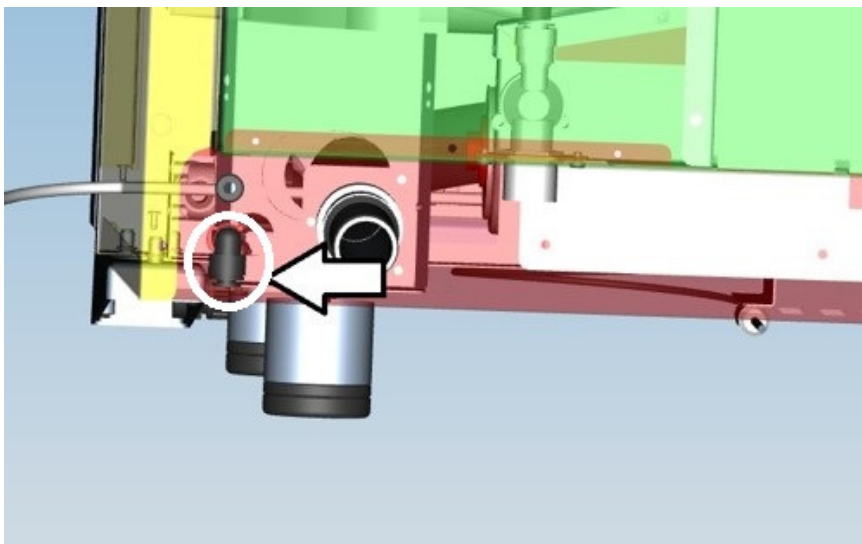
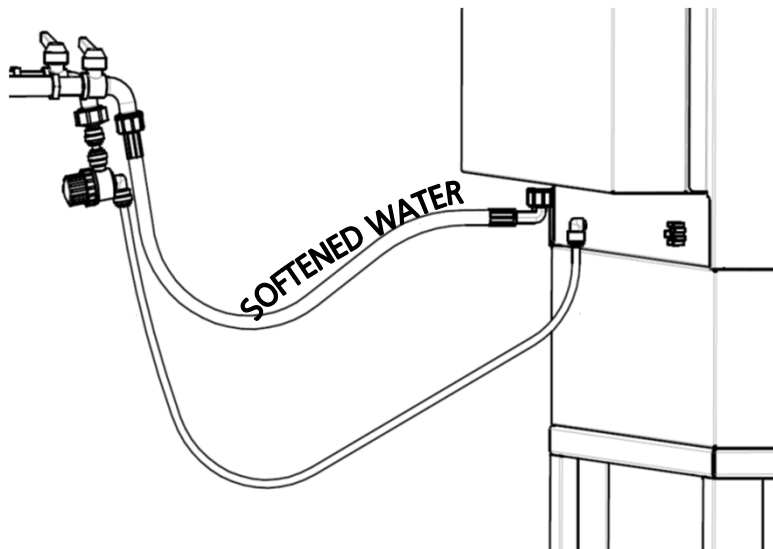

Warning

To handle the detergent and during the maintenance of the washing water circuit, it should be used the appropriate DPI (garments, splash visor, gloves, goggles) : strictly follow the instructions on the detergent safety data sheet.

DRAINAGE CONNECTION

A drain pipe comes out of the rear of the appliance to drain the cooking chamber. This pipe must be connected to piping with 30 mm internal diameter (DN 30) resistant to steam temperatures (90°C-100°C); it's suggested to avoid the metal ones.

The piping must be rigid and must not have bottlenecks along the discharge path (it's advisable to use commercial pipes made of special plastic material, with an internal "sealing" O-RING, and limit the use of "elbow" bends).

The piping must also maintain a constant slope (min. 4-5%) along its entire length.

The considered length is from the drain pipe of the appliance to the discharge point and must not exceed 1.5 meters.

It is mandatory to connect the appliance's drain to the sewerage through an adequate syphon, in order to stop steam/odours from going back in the cooking chamber. The drainage connection must be set up separately for each appliance; with multiple appliances connected to the same drain pipe, ensure that the pipe is sized to assure smooth runoff without hindrances.

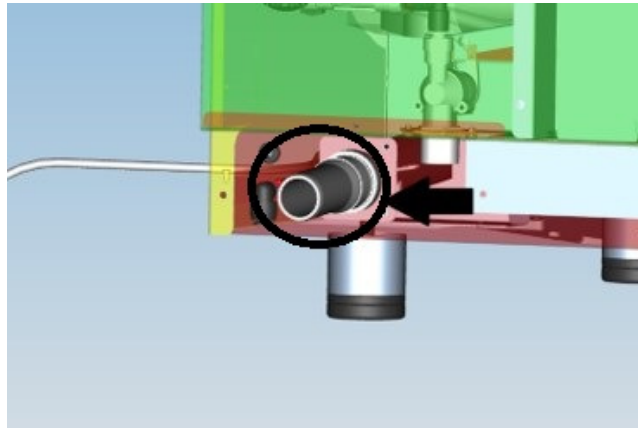

Water drain for floor-standing ovens

The drain pipe is conveyed to an open (grilled) drain on the floor and should not go into direct contact with the discharge point: the "air gap" (distance between the drain pipe coming from the appliance and the open drain) must be at least 25 mm.

Wall-mounted discharge is also allowed as long as the drain pipe maintains the steady gradient of 4-5%.

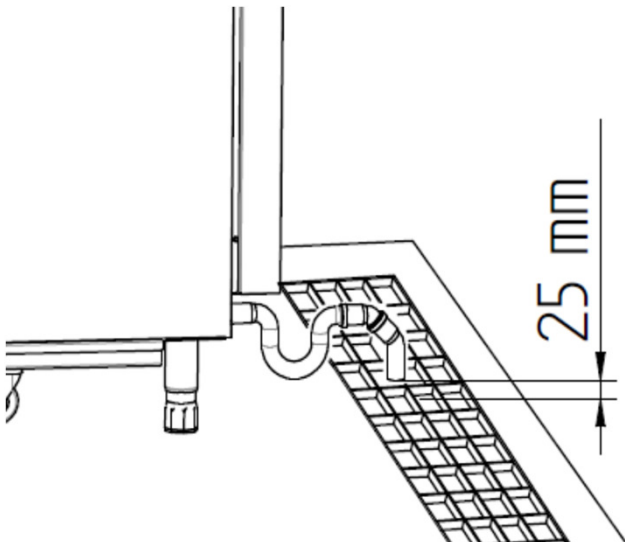

Water drain for tabletop ovens

The drain pipe can be conveyed to an open (grilled) floor drain; otherwise, between the drain pipe of the appliance and the drain point with a "collection vessel", there must be a height difference of at least 30 cm in order to facilitate the regular flow of water. In any case, the "air gap" (distance between the drain pipe from the appliance and the open drain or the "collection vessel" of the drain duct pipe) must be at least 25 mm.

Wall-mounted discharge is also allowed as long as the drain pipe maintains the steady gradient of 4-5%.

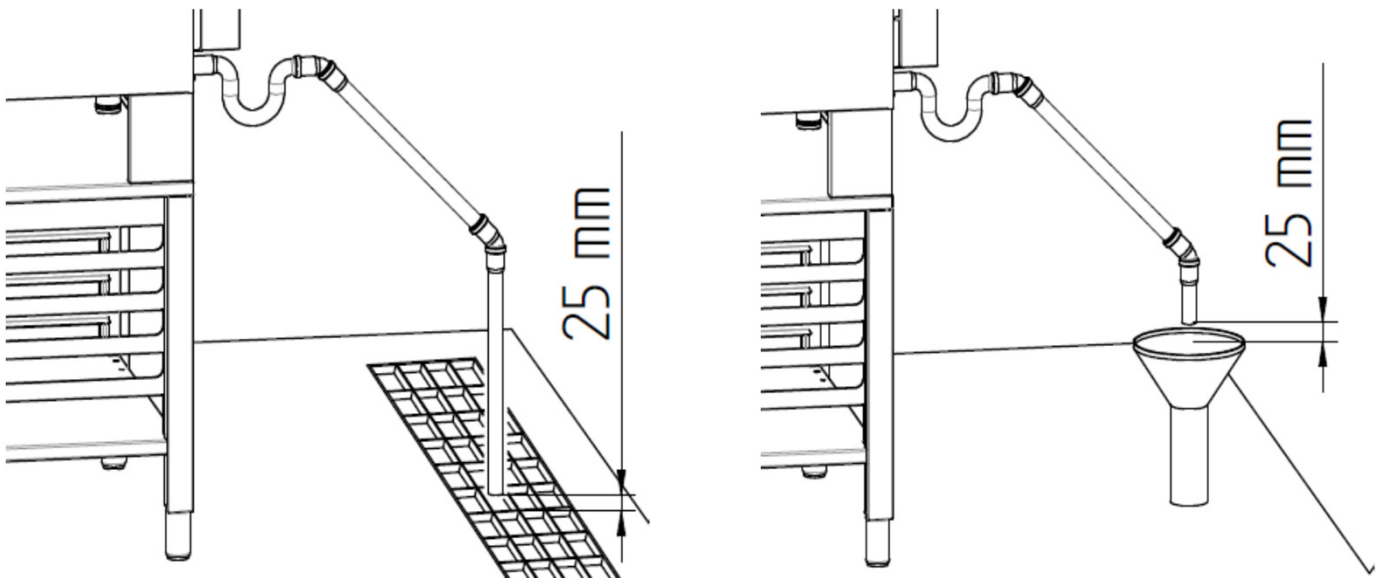

Steam outlet

The appliance is equipped with a special metal tube (DN30), to exhaust the steam from the cooking chamber, which protrudes from the back of the enclosure.

No other type of pipe can be connected to this pipe. Failure to comply with this specific prohibition will allow the Manufacturer to reject any responsibility coming from the possible malfunction of the appliance and the poor quality of the cooking operations.

Increasing the length of the original exhaust pipe may cause abnormal condensation inside the cooking chamber.

To prevent steam from escaping from the exhaust pipe, place the appliance under the extraction hood, or connect it with the "TECNOEKA" condensation hood, specifically designed for the model of appliance in use.

COMPONENTS LOCATION IN THE OVEN

Any maintenance operation on the appliance must only be done by highly qualified personnel trained in the operations being performed and authorised by TECNOEKA. Operations must be carried out in accordance with the safety regulations in force in the country where the appliance is installed, pursuant to the regulations relative to plants and to workplace safety.

Before carrying out any maintenance on the appliance it must be disconnected from the mains and allowed to cool down.

Access to the components for inspection

Removing the right side:

- Magnetic door sensor (right opening)
- Electronic components box (*TS and BM models*)
- Cooking chamber probe
- Terminal board 12V (accessory cable connection)
- Contactors
- Anti-interference filter (if any)

Removing the back:

- Tangential motor (on the back)
- Circular resistors
- Radial motors/Encoder motor (*TS models*)
- Dryer motor (*TS models*)
- Contactors
- Power supply terminal board
- Safety thermostat
- Capacitors
- Humidification solenoid valve
- Humidification piping/fittings unit

for models "V TS" and "V C TS" add:

- *Steam generator*
- *Steam generator safety thermostat*
- *Steam generator "discharge" solenoid valve*
- *Steam generator "charge" solenoid valve*
- *Steam generator piping/fittings unit*

Removing the left side:

- Magnetic door sensor (left opening)
- Peristaltic washing pump (*TS and BM models*)
- Washing solenoid valve (*TS and BM models*)
- Washing piping/fittings unit (*TS and BM models*)

Pulling the LED bar protection box (on the door):

- LED Bar
- Display (*TS and BM models*)
- Encoder board (*TS models*)

HOOD INSTALLATION FOR TWO STACKED OVENS

When you have to install two stacked ovens with an hood, TECNOEKA will supply the kit MKKCKIT.

Here below a photo explanation of the procedure. A video is also available, you can ask for it sending an email to the SERVICE DEPT.

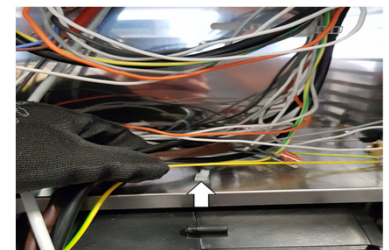
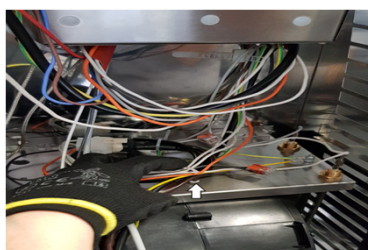
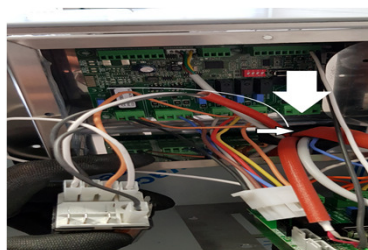
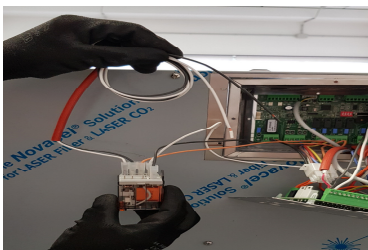
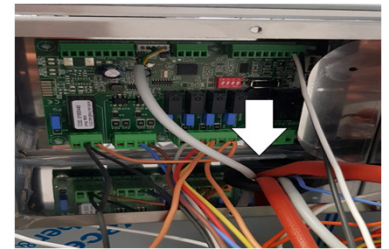
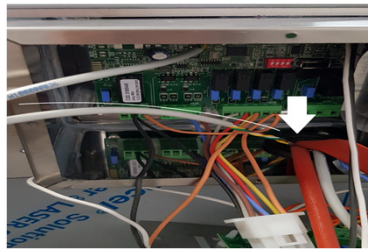
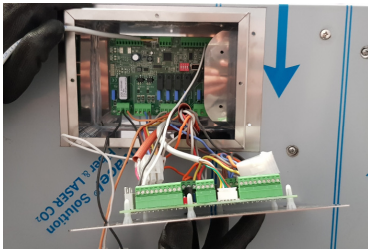
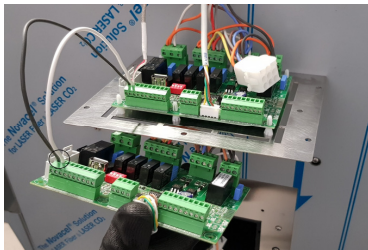
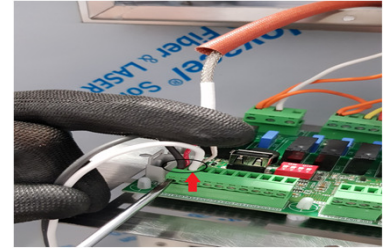
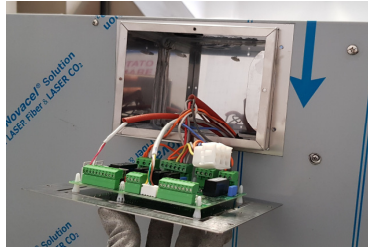
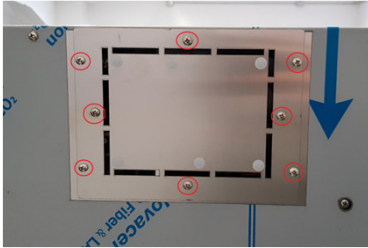

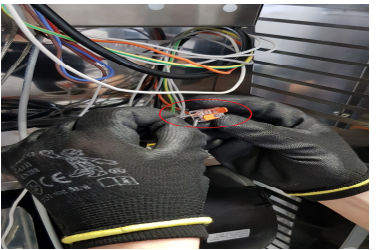
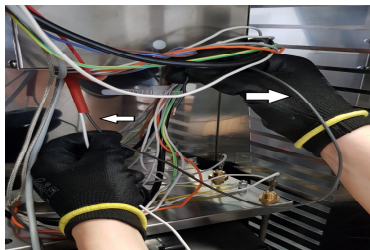
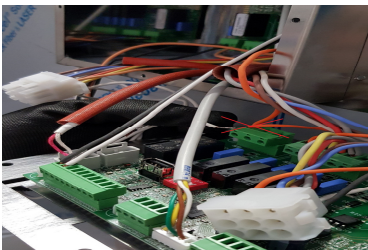
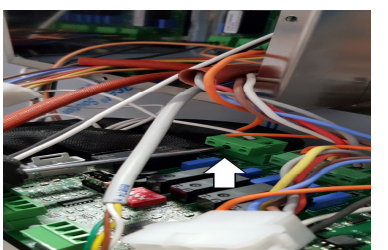
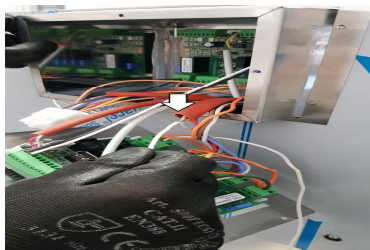
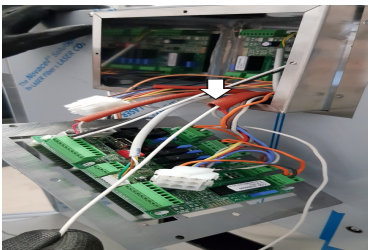
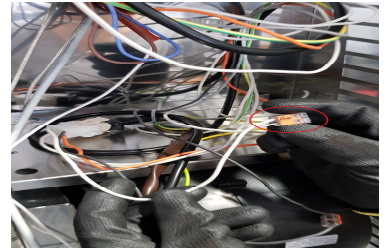
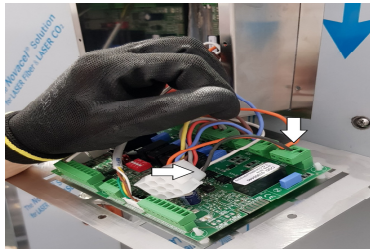
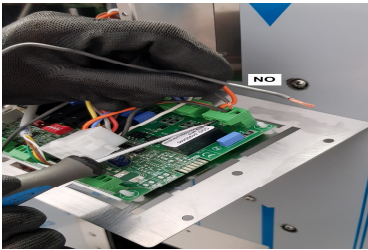
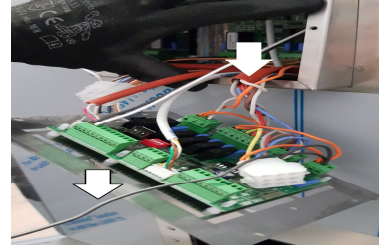
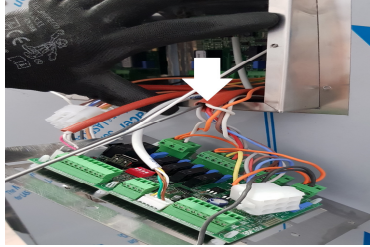
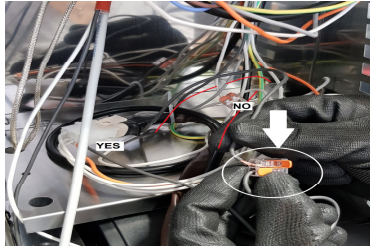
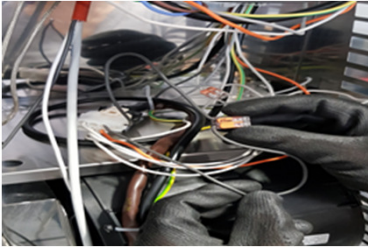

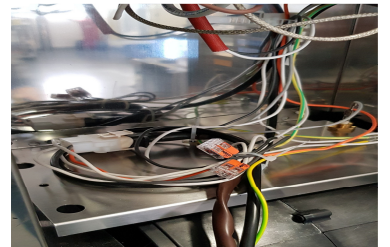
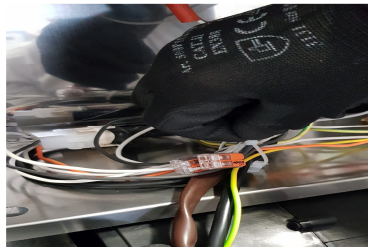
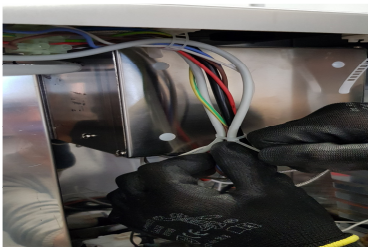
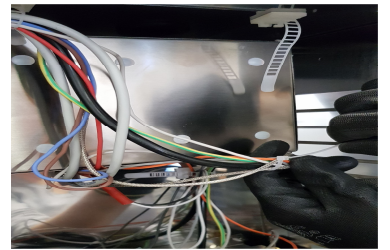
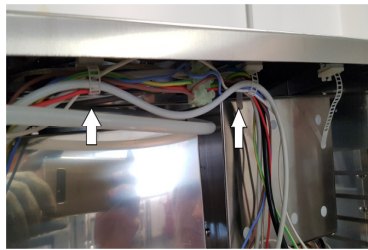
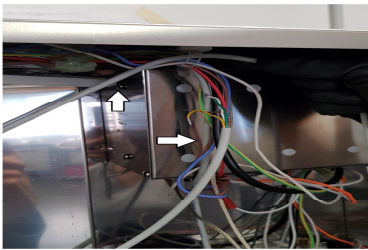
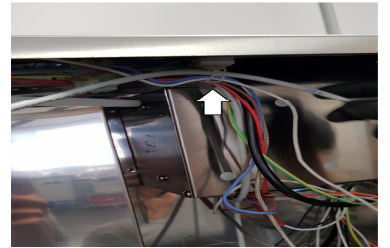
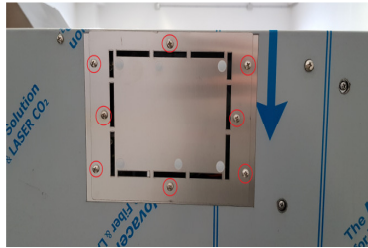
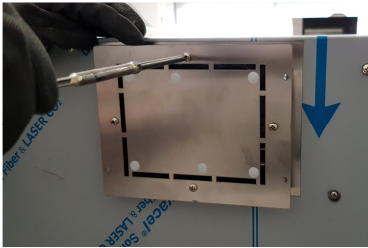
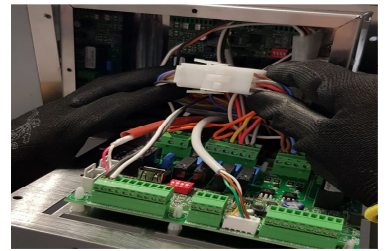
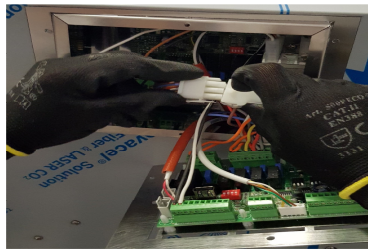
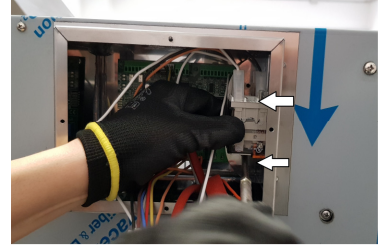
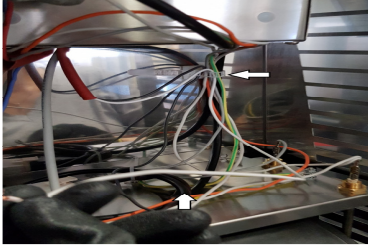
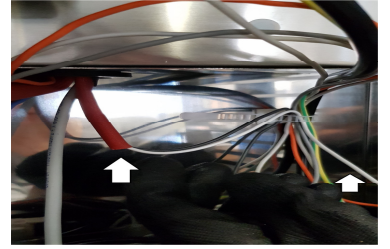
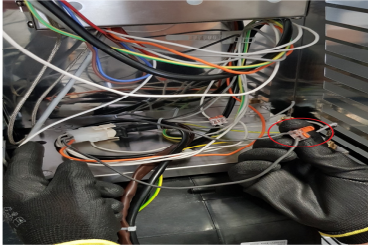

TUTORIAL VIDEO AVAILABLE HERE



GASKET CLEANING PROCESS

1) Pour a little quantity of dish washing soap into a empty bucket, fill it with warm water

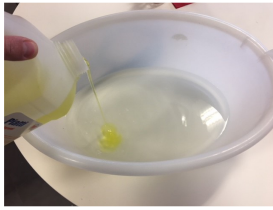

2) Carefully remove the gasket from its place



3) Place the gasket into the bucket and wash it properly, do not leave the gasket immersed for more than 10 minutes



4) Rinse and dry the gasket properly by using a sponge



5) Rinse the gasket location with water and dishwashing soap by using a wet sponge. dry the location carefully



6) Fit the gasket back in place

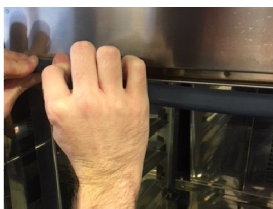

SAFETY THERMOSTAT DEVICE POSITION

The appliance is equipped with a (manually reset) safety thermostat, to protect against excessive and hazardous overheating which might accidentally occur inside it. If the safety thermostat is activated, the power supply to the appliance is cut off.

The safety thermostat is located at the back (bottom) of the appliance; to reset it after it has tripped, unscrew the protective cap using an appropriate tool and press the "reset" button all the way. Replace the protective cap so that it cannot be unscrewed without the use of a tool.

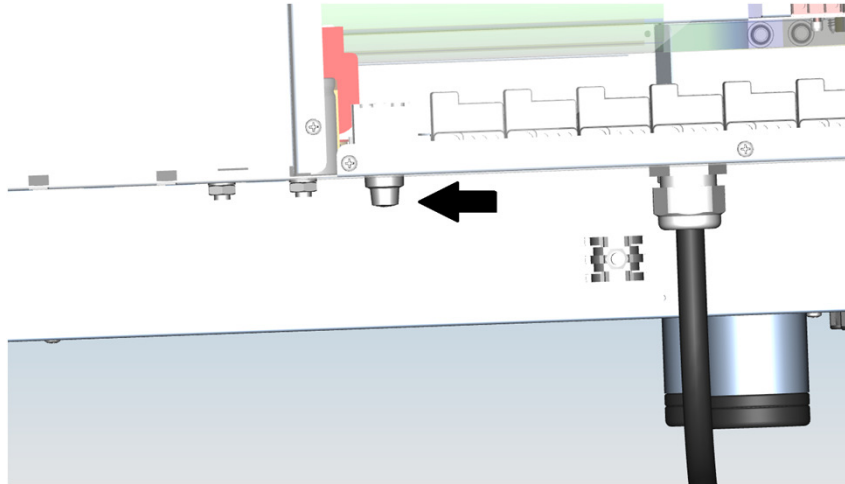

The steam generator for the appliances that include it (versions "V TS" and "V C TS") is equipped with a (manually reset) thermostat for heating resistor overheating protection. If the safety thermostat is triggered, the power supply to the heating resistor is cut off. The safety thermostat is located near the steam generator and is accessed by removing the back of the appliance; to reset it after it is triggered, press the "reset" button all the way.

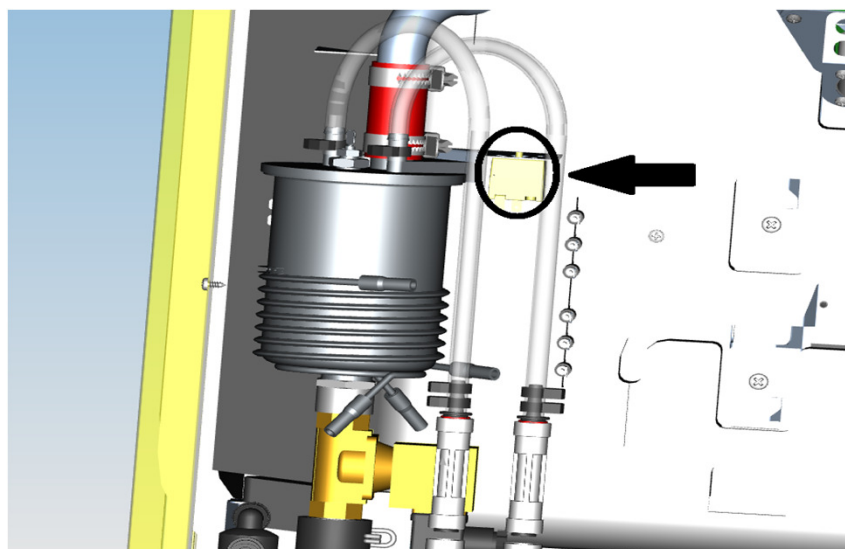

Warning

Safety thermostats should only be reactivated after eliminating the anomaly that caused them to trip.

CABLE ARRANGEMENT FOR ACCESSORIES BOARD

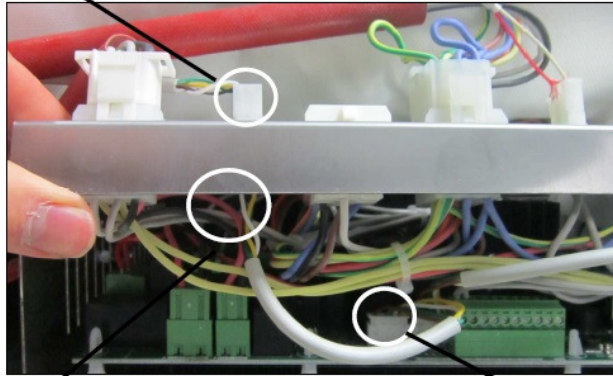
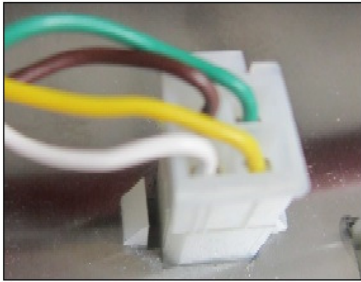

THE CONNECTOR ON THE ACCESSORIES CARD WITH 4 COLORED WIRES MUST BE ARRANGED IN THE SAME ORDER AS THOSE PRESENT IN THE OVEN POWER CARD

OVEN POWER BOARD

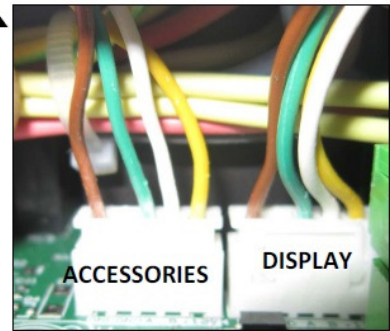
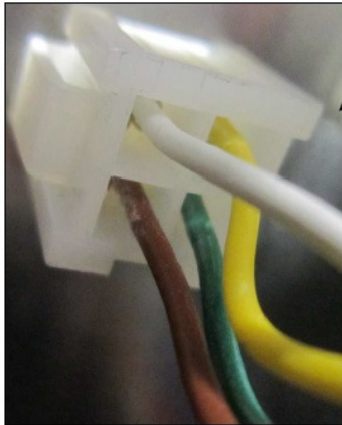

SOFTWARE INSTALLATION AND UPDATE TOUCH SCREEN

If the oven is connected to an internet network via WI-FI, a message will appear everytime a new sotware version is released by the company.

If it's not connected to an internet network or if the software installed have some trouble, here below there is the procedure.

In the Millennial line (just TS and BM) the USB socket is located in the door bracket.



Latest update available at the following link

bit.ly/3FFzTcA

- procure and empty USB stick, max 16gb, format it in FAT32 and keep it empty
- open the zip pack file you received, extract directories and files into the empty USB

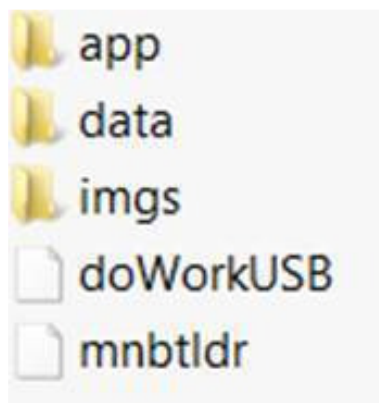

- disconnect the USB from the computer and plug it to the unit which must be turned on
- the update will be confirmed by the screen to automatically reboot and 3 bips issued from the inner buzzer.

Reboot the oven power supply and disconnect the USB pendrive.

SOFTWARE INSTALLATION AND UPDATE BLACK MASK

In the Millennial line the USB unit is located in the door bracket

Latest update available at the following link

bit.ly/3h7LxUt



- procure and empty USB stick, max 16gb, format it in FAT32 and keep it empty
- open the zip pack file you received, extract the file into the empty USB
- disconnect the USB from the computer and plug it to the unit which must be turned off
- turn on the oven and wait for the update

Reboot the oven power supply and disconnect the USB pendrive.

DYSPLAY REPLACING

DOWNLOAD THE CLONE TOOL SOFTWARE AT THE FOLLOWING LINK

bit.ly/3EpgNWw

Once you have it:

- extract in an empty USB the files in the zip pack
- Insert the USB in the socket
- on the screen will appear 2 buttons: "IMPORT FROM OVEN" and "EXPORT FROM OVEN"
- touch «IMPORT FROM OVEN»
- when «IMPORT DONE» appears, switch off the oven and remove the USB stick.
- replace the display in the oven
- switch on the oven and connect the USB stick
- In the new display will appear the same buttons of point 3
- Touch «EXPORT TO OVEN»
- When «EXPORT DONE» appears, switch off the oven and remove the USB stick.
- Switch on again and all the data from the old display will appear in the new one.

TUTORIAL VIDEO AVAILABLE HERE



WASHING SYSTEM INSTALLATION (FOR BLACK MASK MODELS)

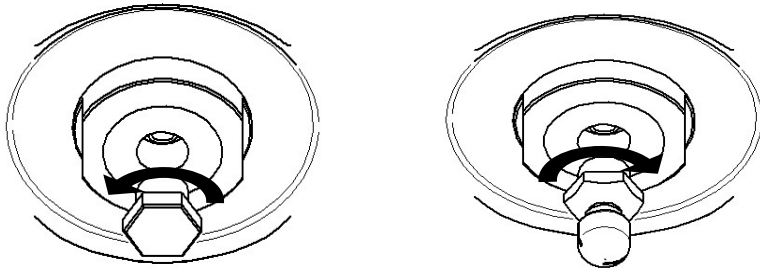

First unscrew the threaded cap from the fixing seat of the self-rotating nozzle on the ceiling of the cooking chamber.

Using the same spanner, screw the self-rotating nozzle into its threaded seat.

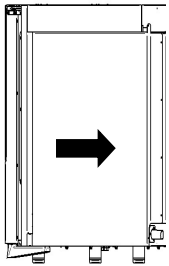

Remove the right side of the oven by unscrewing the self-tapping screws along the rear side.

Remove the side by sliding it towards the rear of the oven: exert adequate traction in the direction of the arrow.

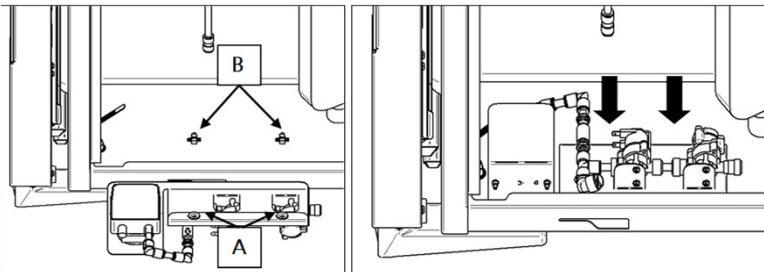

Keep washing system slightly raised, and check that the 2 "snap-on" caps (A) attached to the back of the plate are aligned above the pins (B) on the oven base.

Push down the plate so that the "snap-on" caps are fully inserted on their pins.

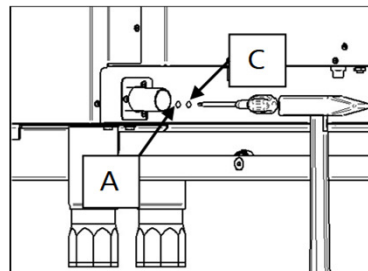
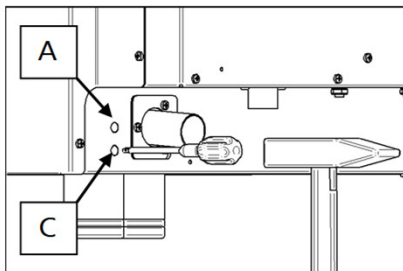

Using an appropriate tool, open the 2 holes on the back of the oven's base.

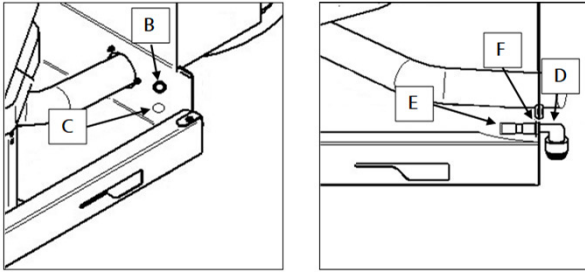

Install the rubber grommet (B) in the hole "A". Through the hole "C", insert the tang of the elbow fitting (D), and holding the fitting between your fingers, insert the straight fitting (E) on the tang. To lock the straight fitting to the tang, insert the "seeger" (F) between the movable part and the fixed part of the quick coupling "JG" of the straight fitting: from the side inserted in the tang.

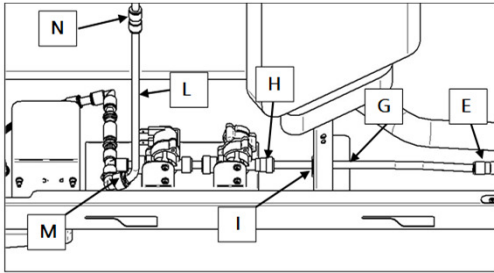

Insert the polyethylene pipe (G) between the valve (H) and the straight fitting (E). The pipe must be passed through the appropriate cable gland (I) on the oven pedestal
Insert the polyethylene pipe (L) between the elbow fitting (M) and the straight fitting (N).

Oven model	Pipe length "G" (mm)	Pipe length "L" (mm)
MKF464BM	450	200
MKF511BM	230	150
MKF611CBM	500	250
MKF623CBM	180	150
MKF664BM	450	350
MKF621BM	450	350
MKF711BM	230	250
MKF1011CBM	500	500
MKF1064BM	450	600
MKF1021BM	450	600
MKF1111BM	230	600
MKF1664BM	450	1150
MKF2011BM	450	1150

The lengths of the polyethylene pipes "G" and "L", for the various oven models, are shown in the opposite table.

To cut the polyethylene pipes to the indicated size, use a special pipe cutter scissor that allows a precise cut without any burrs.

When inserting the pipe into the couplings, the burrs could damage the rubber "O-rings" inside the "JG" quick couplings (inevitable and dangerous water leaks).

The polyethylene pipes "G" and "L", must be inserted in the "JG" quick couplings keeping them aligned at the inlet of the fittings; otherwise, the rubber "O-rings" inside the quick couplings could be damaged (inevitable and dangerous water leaks).

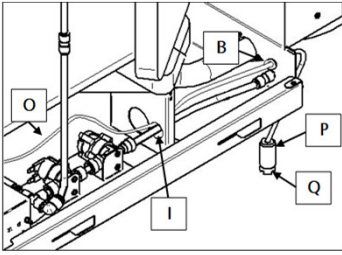

Insert the end part of the nylon tube (O), already connected to the washing system, first through the special hole (I) on the oven pedestal, then through the rubber grommet (B) mounted on the oven base. Then pass it through the hole in the ceramic ballasted cylinder (P), and finally connect it to the draught filter (Q).

Slide the ceramic ballasted cylinder onto the draught filter, and lock it to the filter by applying light pressure.

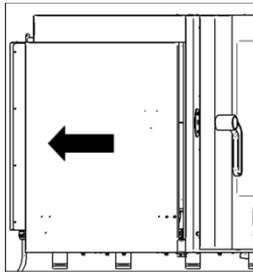

Remove the left side by sliding it towards the rear of the oven: exert adequate traction in the direction of the arrow

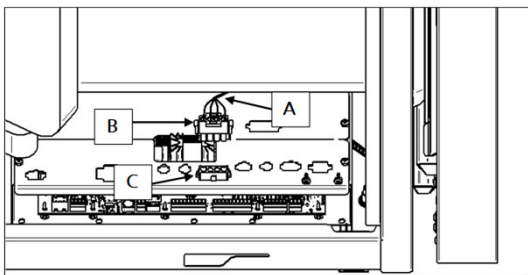

Insert the "4-pin" connector into the relative "4-pin" socket on the "box", and put the left side back in place operating in reverse. Connect to the water mains as explained before.

TUTORIAL VIDEO AVAILABLE HERE



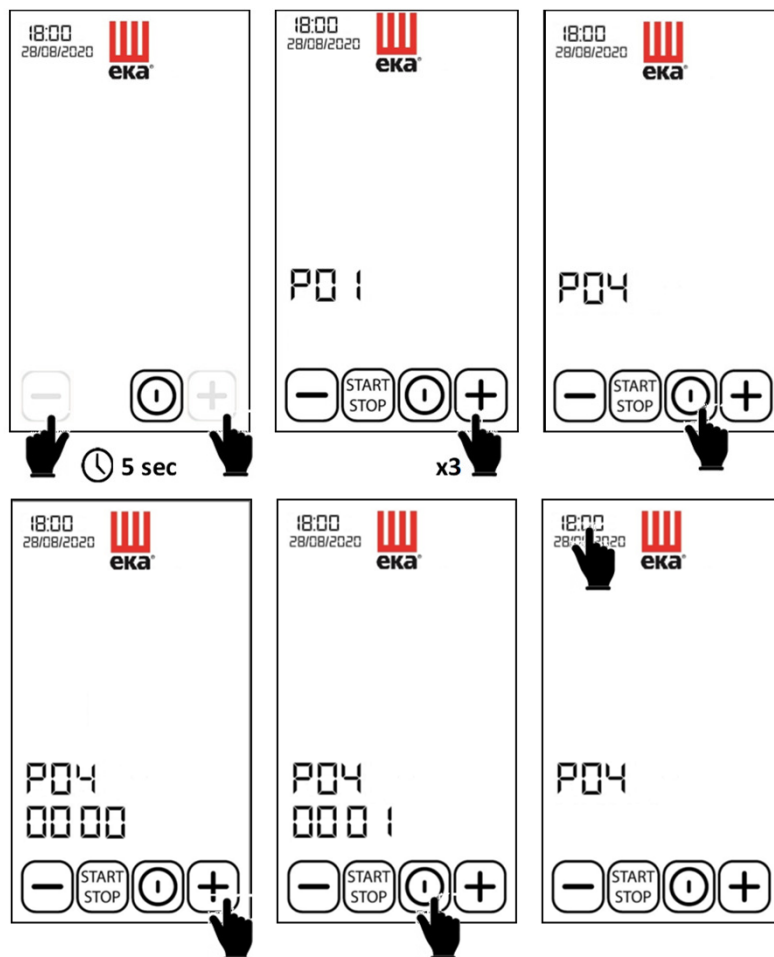

After installing the washing system in the oven, it is necessary to activate its operating function on the display.

From the STAND-BY screen, simultaneously touch the symbols (hidden) \oplus and \ominus (available on the sides of the display) for at least 5 seconds. Touch the symbol \oplus (3 times) until parameter "P04" is selected. Touch the symbol \odot to confirm the selection of the parameter and make it operational. Touch the symbol \oplus to set the washing activation code: from "0000" to "0001". Touch the symbol \odot to confirm the activation of the wash. Finally, touch the time digits (on the display at the top) to return to the STAND-BY screen.

Type of fault	Cause of the fault	Corrective action
After selecting a washing program and activating "START", the program does not start (the control panel display reads: E10)	– The temperature in the cooking chamber exceeds 90°C; therefore, it is not possible to run the selected program	– Wait for the temperature inside the cooking chamber to drop below 90°C. (To speed up the cooling of the cooking chamber, use the "COOLING" program)
The cooking chamber is not washed properly	– The detergent used is different from the one supplied by the Manufacturers	– Exclusively use the detergent supplied by the Manufacturers
	– Detergent has run out	– Use a new detergent canister
	– No water gets to the self-rotating nozzle	– Ensure the washing system water inlet is not obstructed
	– The detergent pump does not work	– Check it and change it

TOUCH SCREEN CONTROL PANEL

1- 7" Touch Screen Display

2- Knob with "PUSH" function

1

2

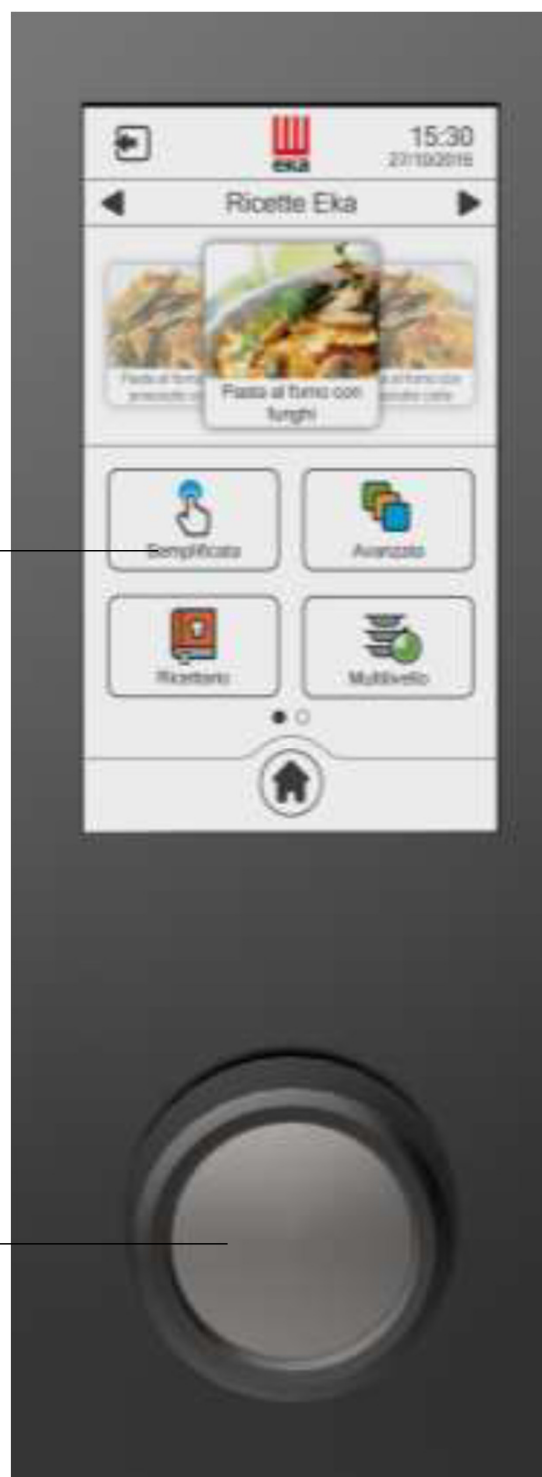

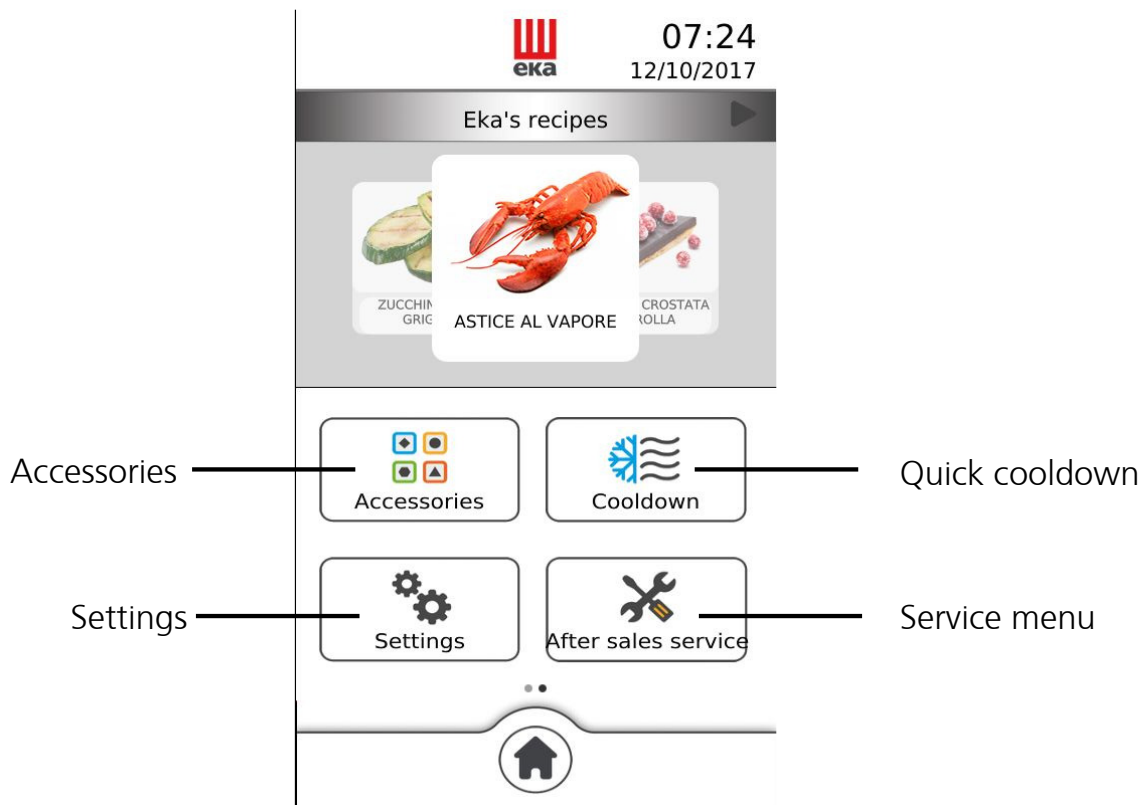
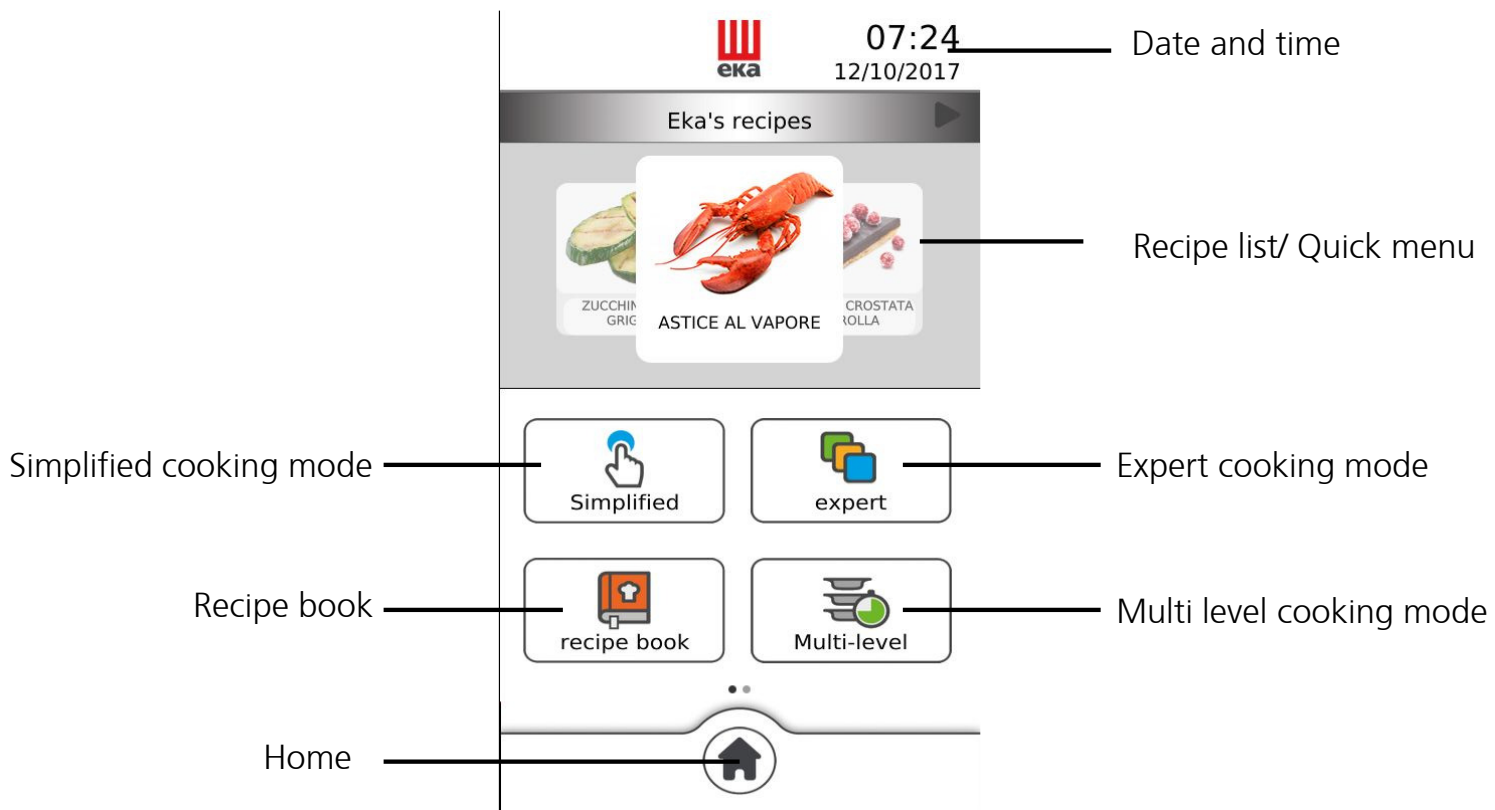

Using the Touch Screen display



TOUCH (confirms the active function, the selected operating parameter and the corresponding set value)

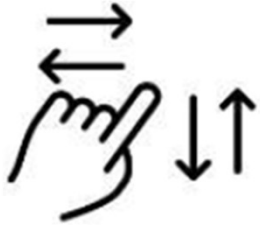

SCROLL (selects the active function and the set parameter value)

Examples:

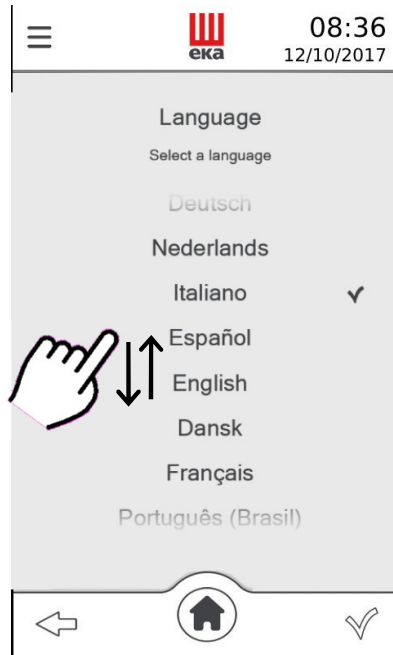
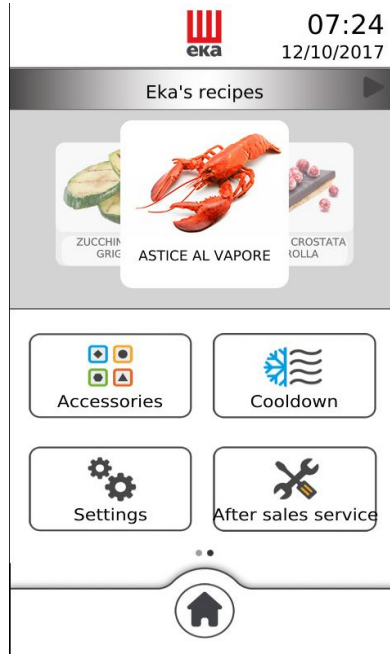

Using the knob



PRESS THE KNOB
(confirms the active
function, the selected
operating parameter
and the corresponding
set value)







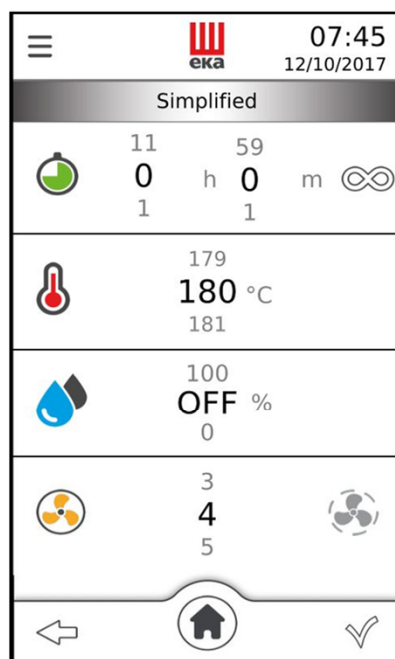
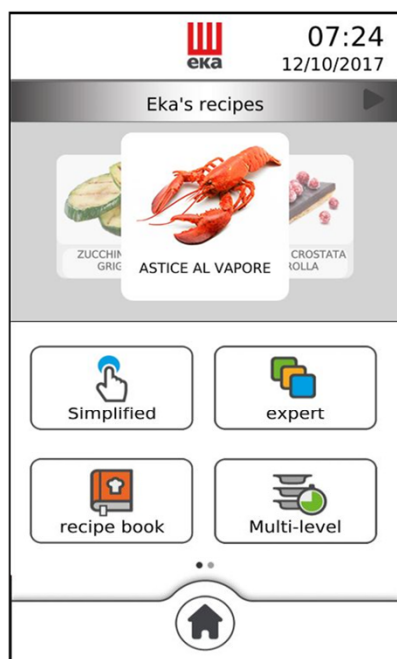







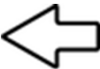

TURN THE KNOB
(changes the active
function, the selected
operating parameter
and the
corresponding set
value)

Examples:











By turning the knob clockwise, you can select the various active functions and the values of the operating parameters in sequence. Pressing the knob again confirms the active function and the value of the operating parameter.

EXPLANATION OF THE SYMBOLS

	CONFIRM	Confirms the set operating parameter
	START	Starts the cooking cycle
	STOP	Stops the cooking cycle
	BACK	Goes back to the previous screen
	HOME	Goes back to the main screen
	ADDITIONAL FUNCTIONS	Accesses the additional functions
	ON	Activates the indicated function
	OFF	Deactivates the indicated function
	ADD	Adds a baking level when using the "Multilevel" function/add cooking steps
	DELETE	Deletes the unwanted data inside the selected function
	"BROWSE" THE VARIOUS MENUS/NAVIGATE BETWEEN THE VARIOUS MENUS/WINDOWS	"Browse" the data of the various menus + ADD COOKING STEPS
	RECIPE NOT SAVED IN THE RECIPE BOOK	The set recipe is not saved in the recipe book
	RECIPE SAVED IN THE RECIPE BOOK	The set recipe is saved in the recipe book
	RECEPTIVE MENU	The recipe list is sorted by type
	ADDITIONAL INFORMATION	Displays additional information (if any)
	STOP "COOLING" or "WASHING"	The "COOLING"/"WASHING" function stops

Operating parameters

	COOKING TIME	from 1 minute to 11 hours and 59 minutes or INFINITE (∞ = OFF ∞ = ON)
	COOKING TEMPERATURE	from 30°C to 270°C
	CORE TEMPERATURE	from 0 to 100°C (only in "Expert Mode")
	ΔT TEMPERATURE	from 0 to 100°C (only in "Expert Mode")
	HUMIDITY	from 0 to 100% with 10% step or OFF
	FAN SPEED	from 1 to 5
	SEMI STATIC	from 1 to 5
	MANUAL HUMIDIFICATION KEY	Humidification always active
	MANUAL DRYING KEY	Drying always active



INSIGHTS

- **"SEMI-STATIC" MODE**

"Semi-static" baking is a mode that allows motors to be activated only when the heating elements are operating.

The mode is activated by touching the  symbol on the display.

The fans are activated in order to distribute the heat generated by the heating elements and make the temperature inside the cooking chamber even.

In this way static oven operation is reproduced.

- **HUMIDIFICATION/ DRYING OPERATION**

Using the algorithms, the oven is able to detect the actual percentage of humidity/steam in the cooking chamber. This independently activates drying or humidification. If, for example, there is 80% of humidity in the cooking chamber and a value of 20% is set on the display, the oven automatically detects that the humidity present is greater than that set and so independently activates the drying system; otherwise, if a higher value of humidity compared to that detected in the cooking chamber is set on the display, the oven independently



PRE-HEATING

The **"PRE-HEATING"** function can be enabled or disabled by the user; when enabled, there is an automatic increase of 40°C of the set cooking temperature.

If, for example, a temperature of 180°C is set ("Phase 1"), the **"PRE-HEATING"** function will allow reaching the temperature of 220°C inside the cooking chamber. A buzzer warns that this temperature has been reached and the display shows the following message: **"PRE-HEATING OK OPEN THE DOOR"**. The temperature is maintained until the door is opened.

Open the door, put the food in the oven, close the door: the cooking cycle starts automatically.

The "PRE-HEATING" function cannot be used together with the delayed start.

The pre-heating temperature cannot exceed 270°C.



MAINTENANCE

The **"MAINTENANCE"** function can be enabled or disabled by the user; when enabled in the cooking program, it becomes operational in the last step of the program and it consists in maintaining the temperature inside the cooking chamber at 80°C. This function is used to keep food warm at the end of cooking, for as long as necessary. It stops when the door is opened.



POSTPONE

The **"POSTPONE"** function can be enabled by the user in the cooking program; when enabled, it allows a "delayed" start of the cooking cycle: useful for products that must be allowed to rise before being cooked.

The "delayed" start can be preset for a time between 1 minute and 11h and 59'. During this time only the cooking chamber lighting is active.

This function cannot be enabled together with "pre-heating".

“HOME” screen

The “Home” screen appears once the first switch-on procedure is completed.

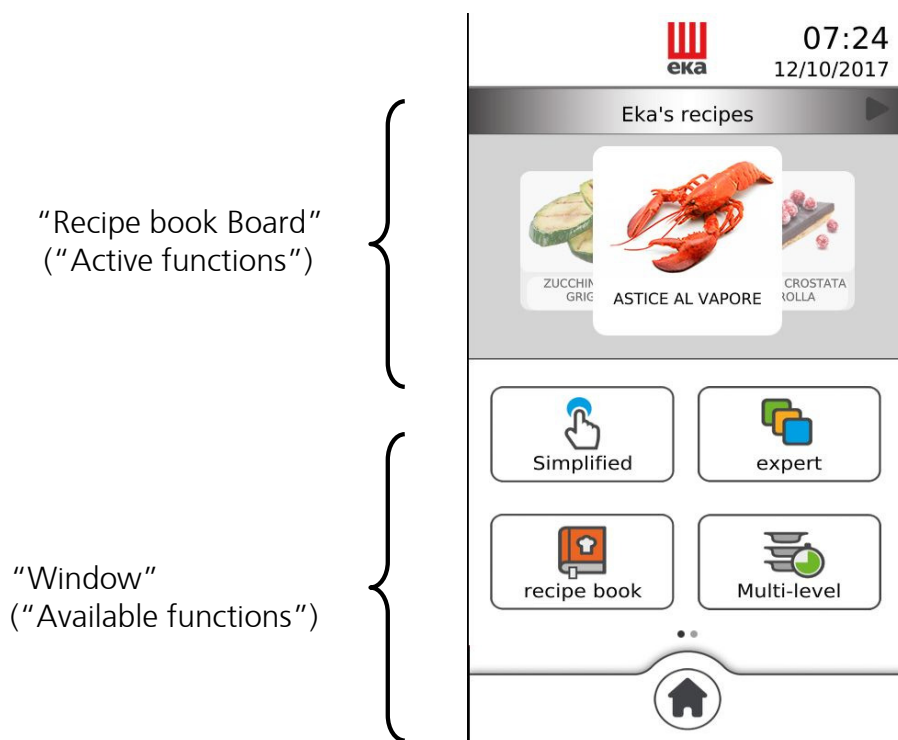

The “active functions” are those used by the oven.

The “available functions” are those that can be potentially used by the oven for its operation.

And they are:

SIMPLIFIED MODE

EXPERT MODE

RECIPE BOOK

MULTI LEVEL

ACCESSORIES

COOLIDOWN

SETTINGS

TECHNICAL SERVICE

The “Home” screen can be activated whenever the “” symbol is touched.

COOKING PROGRAM SETTINGS

Pressing SIMPLIFIED or EXPERT the oven get ready for the «COOKING MODE», so it's possible to scroll between the parameters to set up the cooking program.

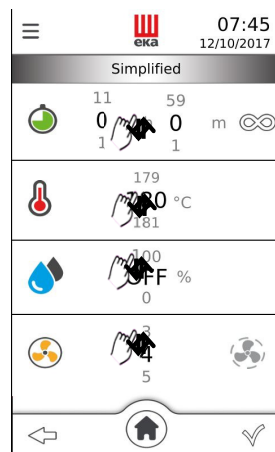

Pressing the button indicated in the side picture, preheating and holding options can be set. Press *confirm* to go back to settings and *confirm* again to see the recap screen.



This is the recap screen, there are all the parameters that has been set before. Press *confirm* to start the cooking

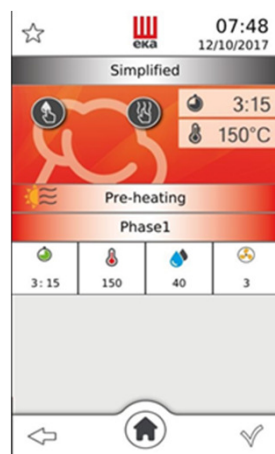

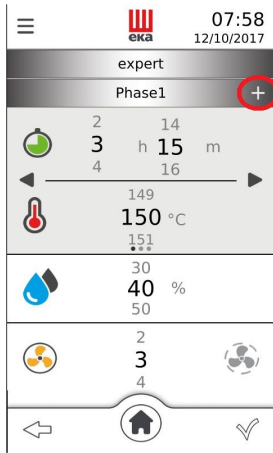

In EXPERT mode it's possible to set multi-phases cooking, pressing the «+» on the right. The oven supports up to 10 phases in the same cooking program.

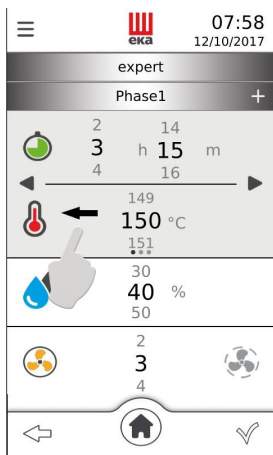
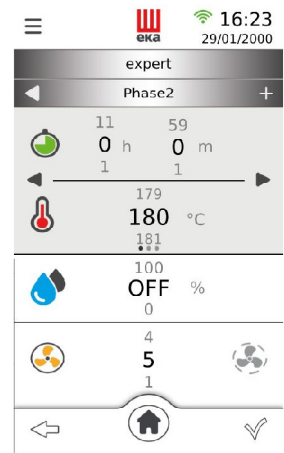

Scrolling on the left, it's possible use and set the core probe instead of the time. It's necessary to connect the core probe from the beginning, even if the setting is later than the first phase.

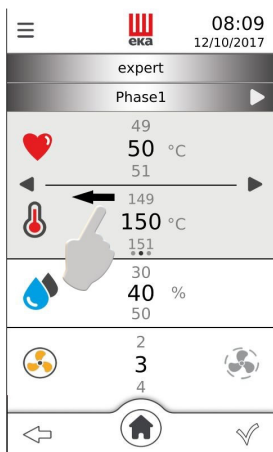
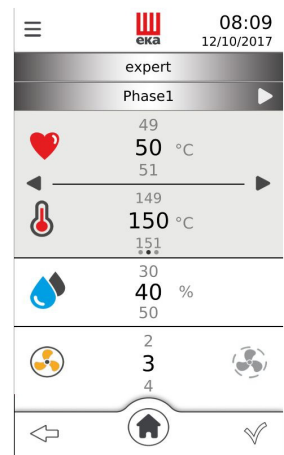

Scrolling again, there is the «Delta T» cooking option, where the oven increase the chamber temperature accordantly with the difference to the food core temperature.

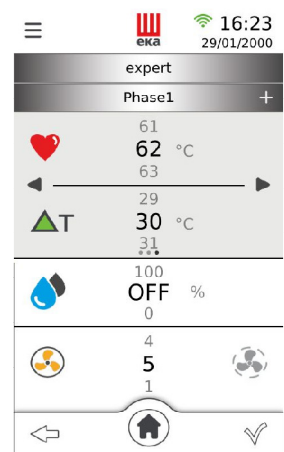

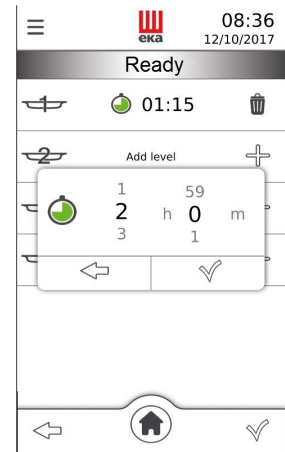
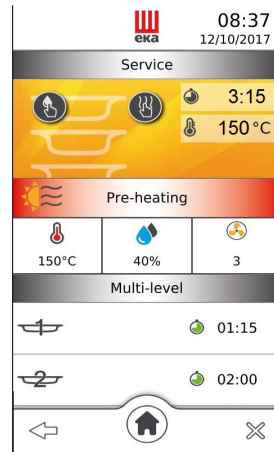
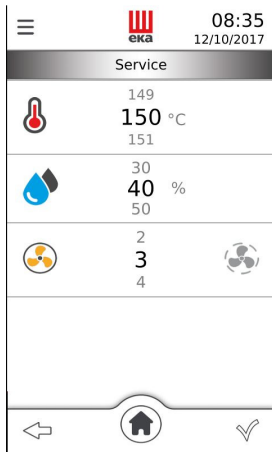

In the «MULTILEVEL» mode, the time will be set after the recap, so there will be as many timers as the oven trays with the same cooking settings.

MANUAL HUMIDIFICATION AND DRYING

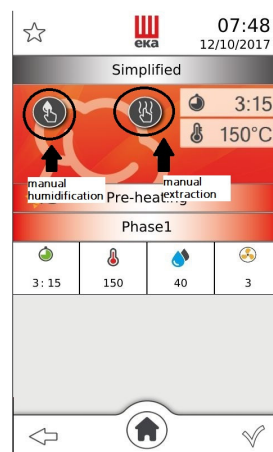

During the cooking process the set parameters can be bypassed by using the two buttons highlighted in the figure above.

Using the manual humidification and drying the encoder that control the cooking chamber conditions is disabled.

They are not timed buttons, the oven works with «manual settings» until the button is pressed again.

Pressing the one on the left it will start the «continuous humidification», this means that the humidification valve will always remain open.

Pressing the one on the right it will start the «forced extraction», a little fan will continuously push out humidity from the cooking chamber and from the food.

HOW TO CORRECTLY SET THE HUMIDIFICATION PARAMETERS

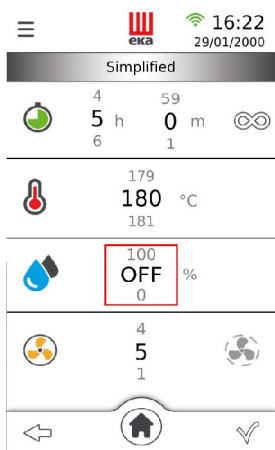

Setting the humidification to «OFF» means that there will be no entry or exit of steam from the cooking chamber. The oven will cook the dish using the moisture naturally present in the food.

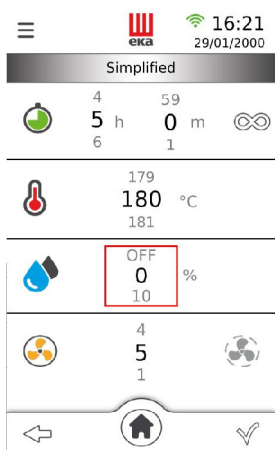

Setting the humidification to «0%» means that the *DRYLOGIC* is on, so all the steam will be forced out, until the cooking chamber is completely dry.

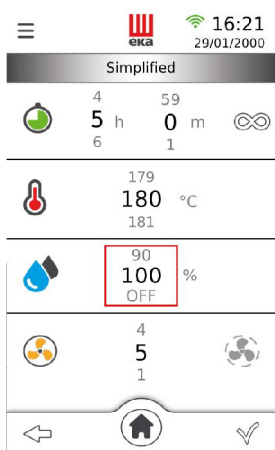

Setting the humidification to «100%» means that the *HUMILOGIC* is on, so the cooking chamber will be full of steam.

Setting the humidification from «10%» to «90%» means that the *AIRFLOWLOGIC* is active and it constantly calculate the real percentage of humidity in the cooking chamber, increasing or decreasing it according to the percentage set.

BLACK MASK CONTROL PANEL

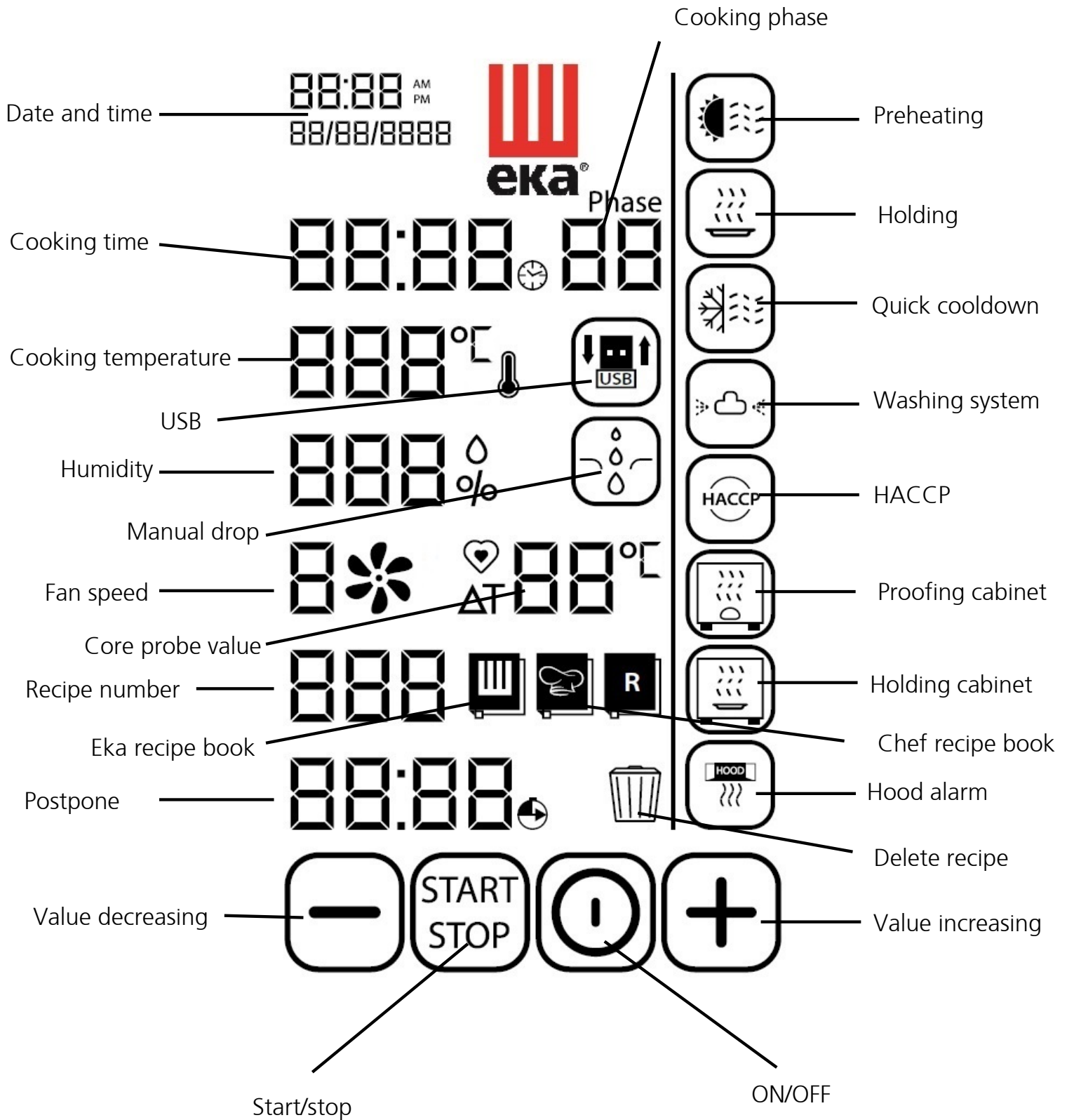

BLACK MASK CONTROL BOARD SETUP

1

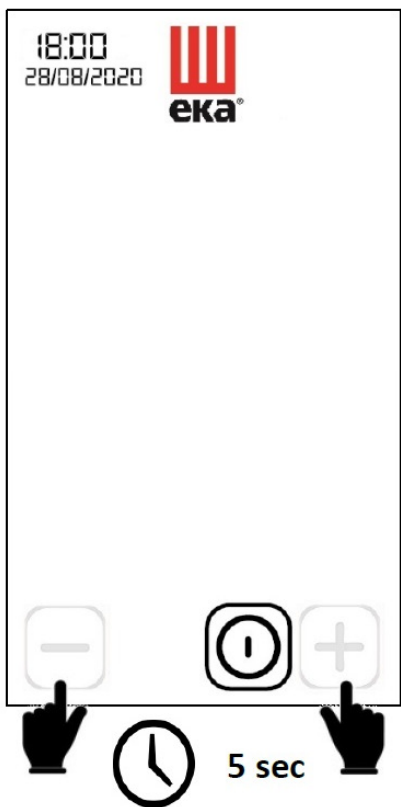

2

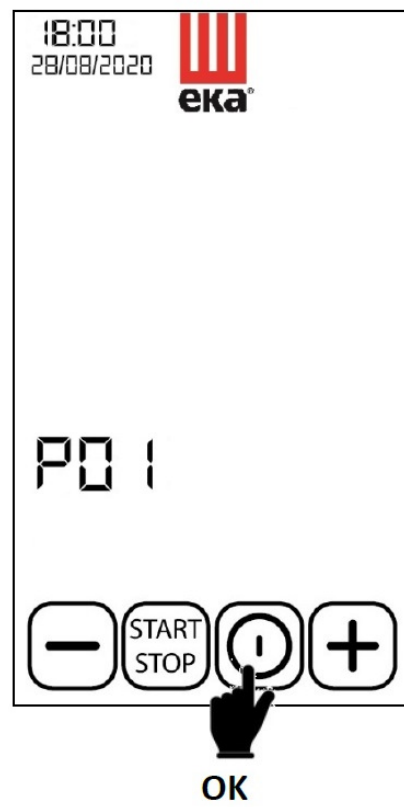

3

SET MODEL

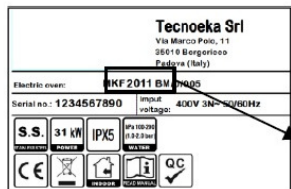

Model	
...464 BM	464
...511 BM	511
...664 BM	664
...616 BM	
...711 BM	711
...1064 BM	
...1016 BM	1064
...1111 BM	1111
...1664 BM	1620
...2011 BM	
...611 CBM	611C
...1011 CBM	1011C
...623 CBM	623C
...621 BM	621
...1021 BM	1021

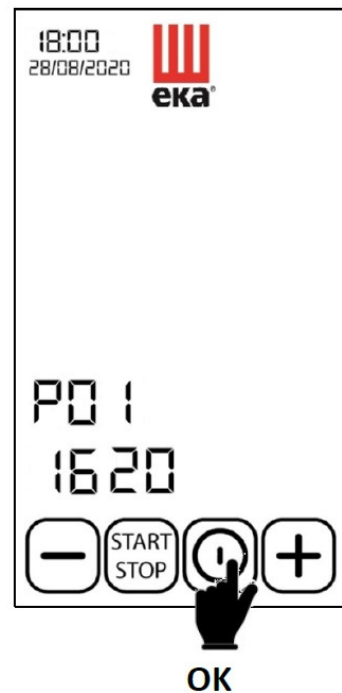
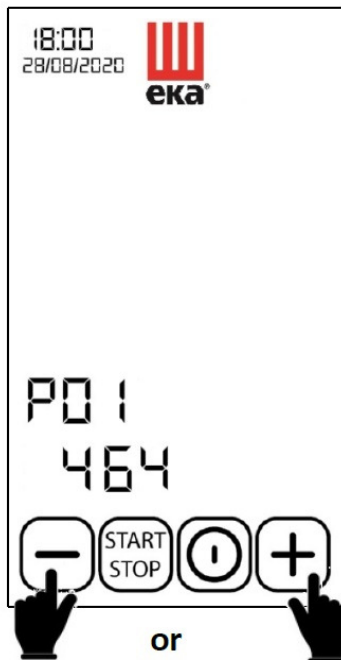

4

SET OVEN GAS

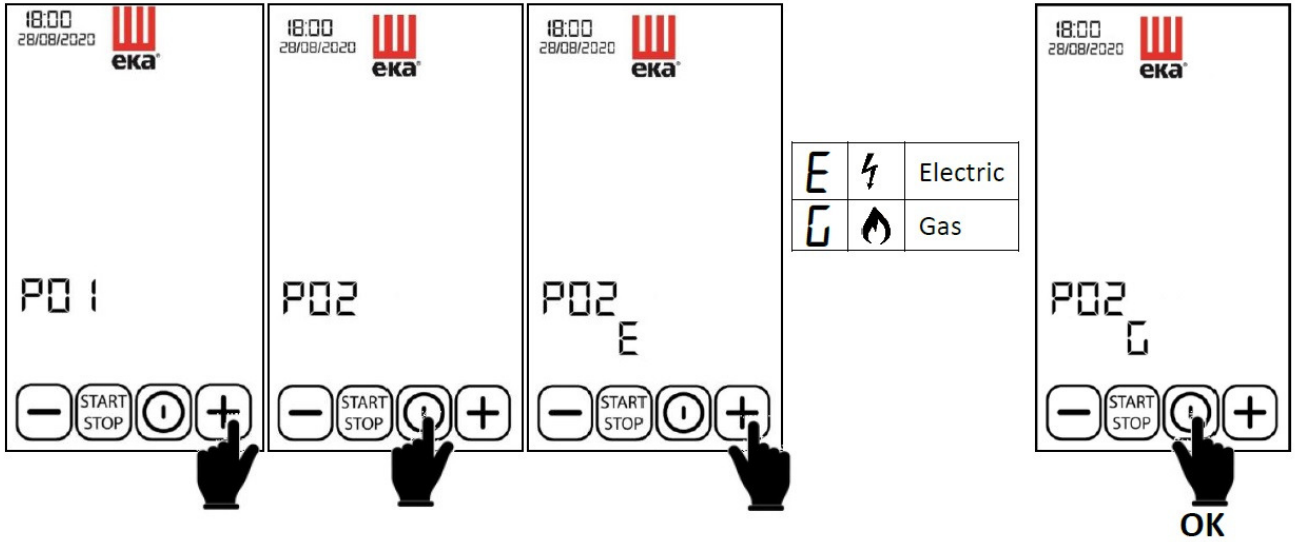

5

SET NO LOGO

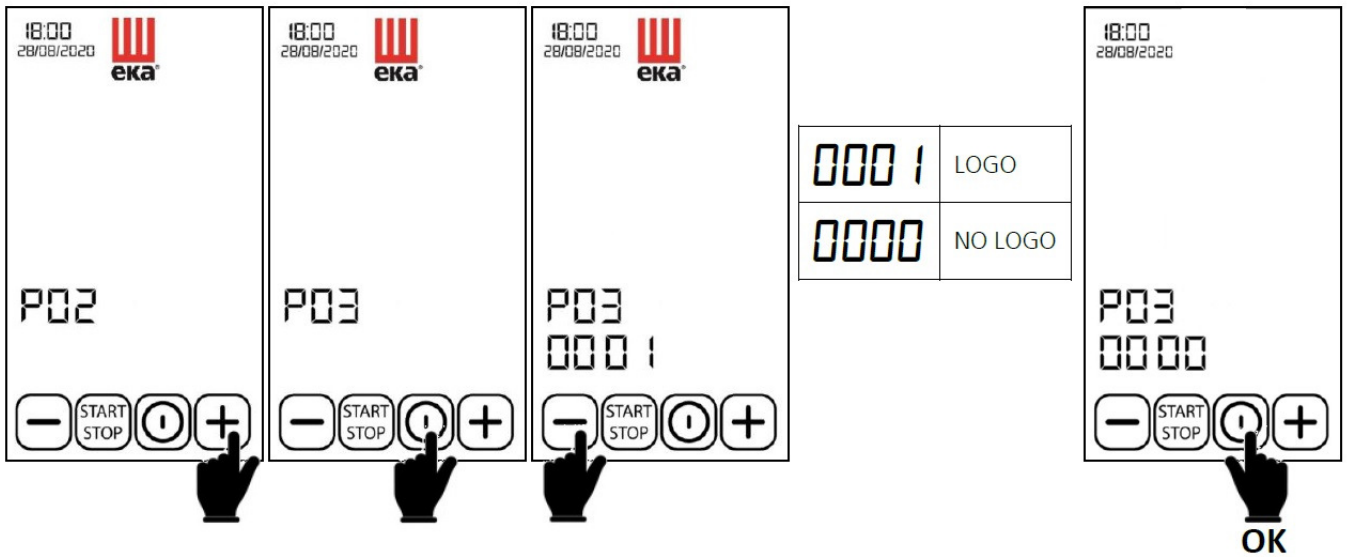

7

SET MKTPL Fat collection kit

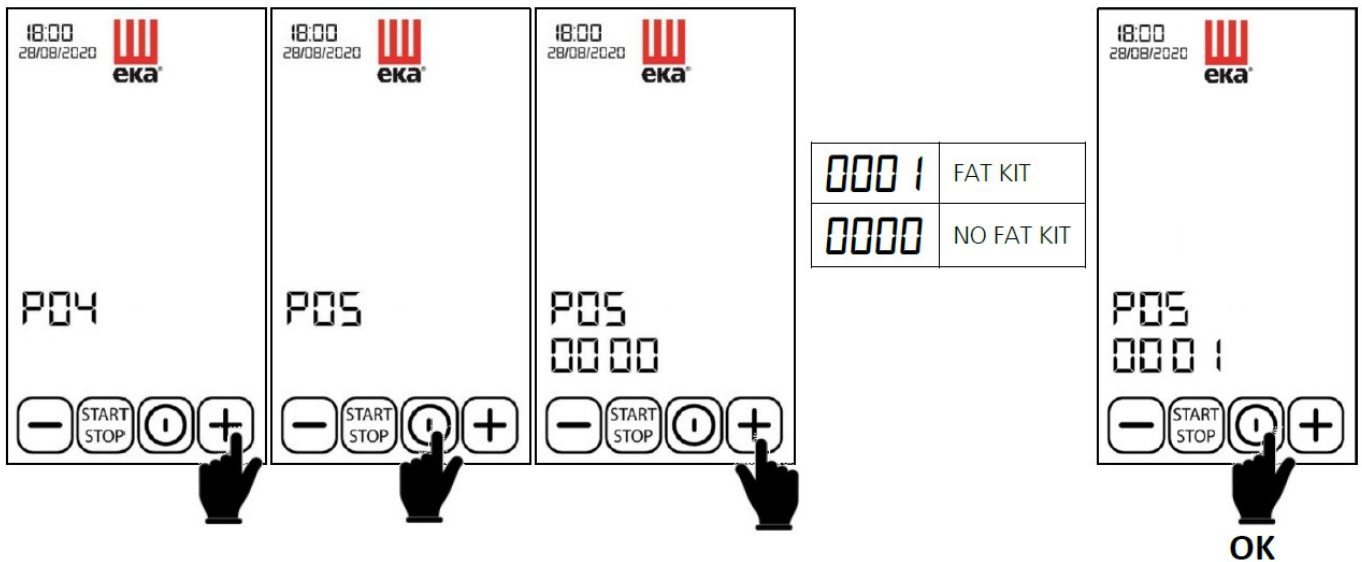

8

ONLY for models 1664G BM – 2011G BM SET TYPE GAS "G30"

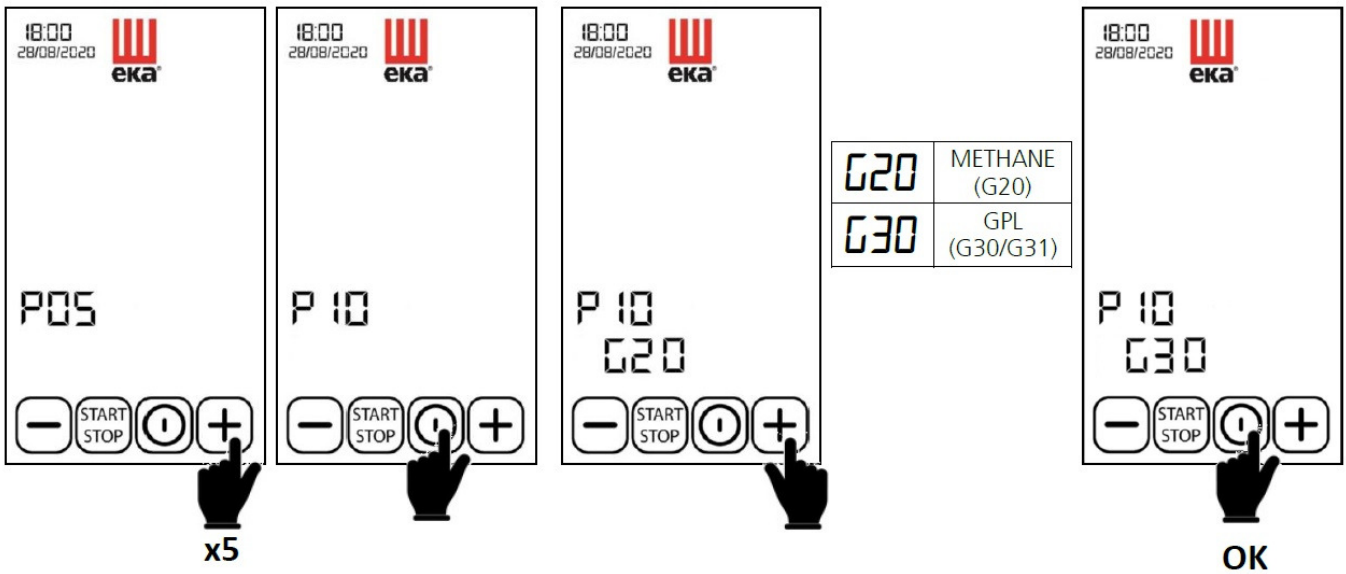

9

EXIT

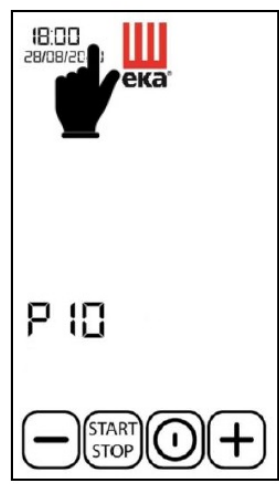

ACCESSORIES AVAILABLE FOR GASTRONOMY OVENS

Accessories available for cooking lines are:

- Holding cabinets (for BM and TS lines)
- Condensation hoods (just for electrical models) controlled by the oven (BM e TS)
- Tables and trolleys



MKM1211

It fits all the models from the 5 trays to the 11 trays.

The holding cabinet is available just for BM and TS lines because is controlled by the oven.



MKKC5

It fits the 5 trays models. For the SMART line the hood is MKKC5S



MKKC711

It fits the 7 and 11 trays models. For the SMART line the hood is MKKC711S



MKKC1620

It fits the 16 and 20 trays models. For the SMART line the hood is MKKC1620S



MKKC623C

It fits the 6 trays 2/3GN compact models.



MKKC610C

It fits the 6 and 10 trays compact models.

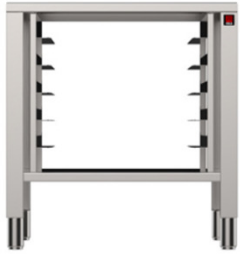

MKTS 11

Fixed table with supports for ovens 5 - 7- 11 trays,
for MKF 511 with kit for overlapping ovens with tray supports MKSST 511;
for MKF 711 with kit for overlapping ovens MKST 711;
for MKF 1111 with kit for overlapping ovens MKS 11



MKT 11 D

Fixed table for ovens 5 - 7- 11 trays (for overlapping ovens),
for MKF 511 with kit for overlapping ovens with tray supports MKSST 511;
for MKF 711 with kit for overlapping ovens MKS 11;
for MKF 1111 with kit for overlapping ovens MKS 11

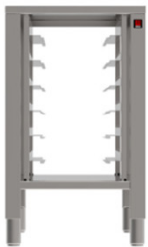

MKTS 623 C

Fixed table with supports, for MKF 623 C
with kit for overlapping ovens with tray supports MKSST 623 C



MKT 623 D C

Fixed table (for overlapping ovens),
for MKF 623 C with kit for overlapping ovens MKS 623 C

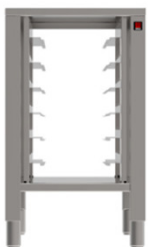

MKTS 11 C

Fixed table with supports for compact ovens 6 - 10 trays,
for MKF 611 C with kit for overlapping ovens with tray supports MKSST 611 C;
for MKF 1011 C with kit for overlapping ovens MKS 11 C



MKT 11 D C

Fixed table for compact ovens 6 trays (for overlapping ovens),
for MKF 611 C with kit for overlapping ovens
with tray supports MKSST 611 C



MKTPL

Closet with kit for fat collection and 2 tanks included 10 lt
for mod: MKF 711 BM, MKF 711 TS, MKF 1111 BM, MKF 1111 TS
(with fat drain)



EKCR 20 TC

Pull-out trolley with removable handle and braked wheels, for 20 trays ovens

ACCESSORIES AVAILABLE FOR BAKERY&PASTRY OVENS

Accessories available for bakery&pastry lines are:

- Proofers
- Condensation hoods (just for electrical models) controlled by the oven (BM e TS)
- Tables and trolleys



MKLM1064S

Electric proofer for 4, 6 and 10 trays ovens S and 1 tray DECK oven



MKLM1064

Electric proofer and holding cabinet for 4, 6 and 10 trays BM and TS ovens, controlled by the oven



MKKC4

It fits the 4 trays models. For the SMART line the hood is MKKC4S



MKKC610

It fits the 6 and 10 trays models.
For the SMART line the hood is MKKC610S



MKKC1620

It fits the 16 trays models. For the SMART line the hood is MKKC1620S

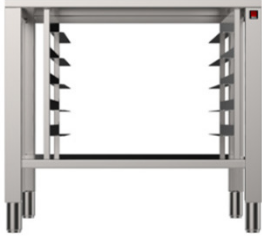

MKTS 64

Fixed table with supports, for ovens 4 - 6- 10 trays and 1 tray DECK oven for MKF 464 with kit for overlapping ovens with tray supports MKSST 464; for MKF 664 with kit for overlapping oven MKST 664; for MKF 1064 with kit for overlapping ovens MKS 64; for MKF D1T with kit for overlapping ovens MKS 64



MKT 64 D

Fixed table, for ovens 4 - 6- 10 trays (for overlapping ovens), for MKF 464 with kit for overlapping ovens with tray supports MKSST 464; for MKF 664 and MKF 621 with kit for overlapping oven MKS 64; for MKF 1064 and MKF 1021 with kit for overlapping oven MKS 64

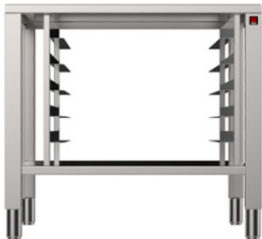

MKTSD 2T

Fixed table with supports, for MKF D2T with kit for overlapping oven MKS 64



EKCR 16 TC

Pull-out trolley with removable handle and braked wheels, for 16 trays ovens



Tecnoeka srl

via Marco Polo, 11 - 35010 Borgoricco, Padova - Italy
Tel. +39.049.5791479 - Tel. +39.049.9300344 - Fax +39.049.5794387

email

info@tecnoeka.com - tecnoekasrl@pec.it

Tecnoeka Iberica S.L.

Cambrils a Reus TV 3141, Km 5,7
43206 Reus (Tarragona)
España
Tel. +34 977 900 198
administracion@tecnoeka.com

Tecnoeka Inc.

3385 Denver Drive
28037 Denver, North Carolina
USA
Tel. +1 704 924-0307
info.usa@tecnoeka.com

Tecnoeka Asia Sdn. Bhd.

No. 32-1, Jalan Puteri 1/2
Bandar Puteri
47100 Puchong
Selangor, Malaysia
Tel. +60 124713100
info.tecnoekaasia@tecnoeka.com

web site

tecnoeka.com

